





COLOR & STRIPE SET FOR EVO 250 EFI

UPDATE : 13-11-2015

	N O	MODEL BASIC COLOR CODE	BLACK		GRAY		WHITE		SILVER			
			BK		GY		W		S			
			BK-433S	Code	GY-517S	Code	WH-300P	Code	S-421S	Code		
	Item	Parts Number	Description		Basic Color	Code	Basic Color	Code	Basic Color	Code	Basic Color	Code
	1	61100-HMA-000	FR FENDER		BK-433S	JG	GY-517S	IP	WH-300P	QU	S-421S	SO
	2	53205-HMA-900	UP HANDLE COVER		BK-001U	KA	BK-001U	KA	BK-001U	KA	BK-001U	KA
	3	64300-HMA-000	FR UNDER SPOILER		BK-433S	JG	GY-517S	IP	WH-300P	QU	S-421S	SO
	4	64301-HWA-000	FR COVER		BK-433S	JG	GY-517S	IP	WH-300P	QU	S-421S	SO
	4	64301-HWA-010	FR COVER		BK-433S	JG	GY-517S	IP	WH-300P	QU	S-421S	SO
	5	81131-HMA-000	INNER BOX COMP		BK-001U	KA	BK-001U	KA	BK-001U	KA	BK-001U	KA
	6	81200-HWA-000	RR CARRIER ASSY		BK-433S	JG	GY-517S	IP	WH-300P	QU	S-421S	SO
	7	81211-HWA-000	RR CARRIER CAP		BK-433S	JG	GY-517S	IP	WH-300P	QU	S-421S	SO
	8	77400-HWA-000	RR BACK SEAT ASSY		BK-433S	JG	GY-517S	IP	WH-300P	QU	S-421S	SO
	9	8125A-HMA-000	LUGGAGE BOX ASSY		BK-001U	●	BK-001U	●	BK-001U	●	BK-001U	●
	10	83501-HMA-000	R BODY COVER GARNISH		S-877U/BK-001U	OL	S-877U/BK-001U	OL	S-877U/BK-001U	OL	S-877U/BK-001U	OL
	11	8350G-HM1-000	R BODY CVOER ASSY		BK-433S	JG	GY-517S	IP	WH-300P	QU	S-421S	SO
	11-1	87126-HM1-000	RH. BODY COVER EMBLEM		●	●	●	●	●	●	●	●
	11-2	87129-HML-000	I MARK		●	●	●	●	●	●	●	●
	12	83601-HMA-000	L BODY COVER GARNISH		S-877U/BK-001U	OL	S-877U/BK-001U	OL	S-877U/BK-001U	OL	S-877U/BK-001U	OL
	13	8360G-HM1-000	L BODY COVER ASSY		BK-433S	JG	GY-517S	IP	WH-300P	QU	S-421S	SO
13-1	87127-HM1-000	LH. BODY COVER EMBLEM		●	●	●	●	●	●	●	●	
13-2	87129-HML-000	I MARK		●	●	●	●	●	●	●	●	
14	8352G-HWA-000	R. SIDE COVER SET		BK-433S	JG	GY-517S	IP	WH-300P	QU	S-421S	SO	
14-1	87123-HWA-000	SYM STRIPE		S-480S	S	S-480S	S	S-480S	S	S-480S	S	
15	8362G-HWA-000	L. SIDE COVER SET		BK-433S	JG	GY-517S	IP	WH-300P	QU	S-421S	SO	
15-1	87123-HWA-000	SYM STRIPE		S-480S	S	S-480S	S	S-480S	S	S-480S	S	
16	88110-HMA-900	R BACK MIRROR ASSY		BK-433S	JG	GY-517S	IP	WH-300P	QU	S-421S	SO	
17	88120-HMA-900	L BACK MIRROR ASSY		BK-433S	JG	GY-517S	IP	WH-300P	QU	S-421S	SO	
STRIPE		Pictures reference only										
11-2/13-2	14-1/15-1	11-1/13-1	11-1/13-1									
												

PRICE SHOWN IS PER PIECE. Product image price are approximate guide only.
Prices shown are subject to change without prior notice.

CONTENTS—ENGINE GROUP

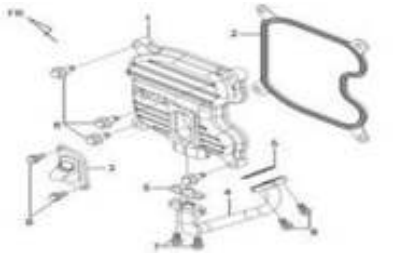
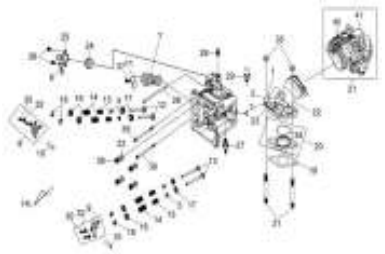
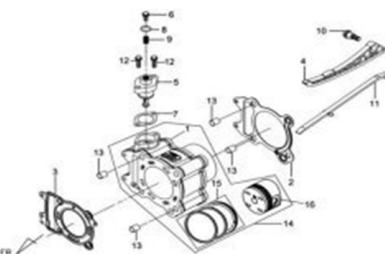
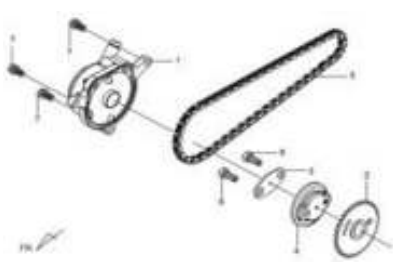
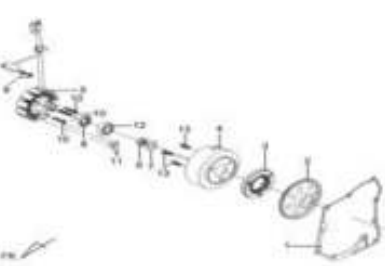
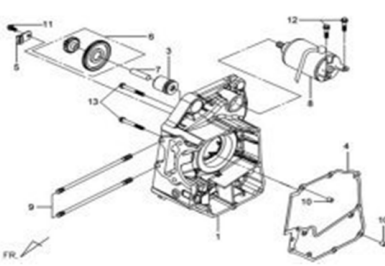
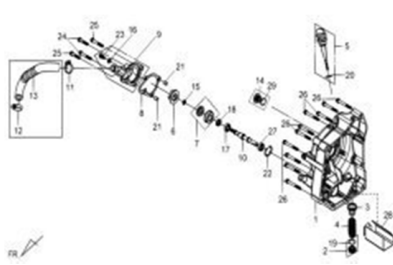
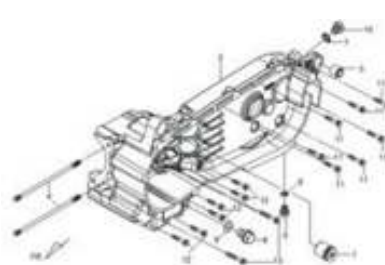
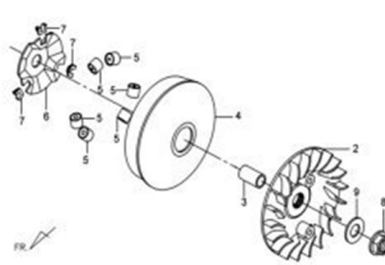
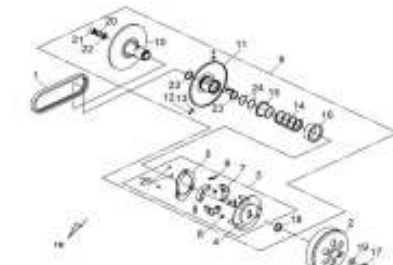
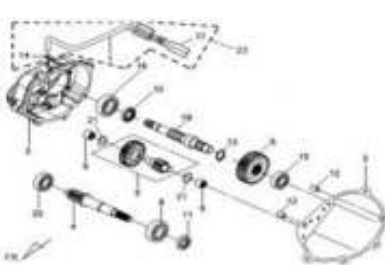
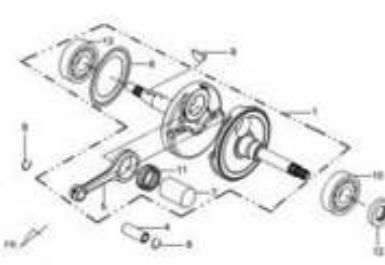
<p>E01 CYLINDER HEAD COVER</p> 	<p>E02 CYLINDER HEAD ASSY</p> 	<p>E03 CYLINDER COMP</p> 
<p>E04 CYLINDER HEAD SIDE COVER</p> 	<p>E05 A.C.G. ASSY</p> 	<p>E06 R. CRANK CASE COMP.</p> 
<p>E07 R. CASE COVER</p> 	<p>E08 L. CRANK CASE COMP.</p> 	<p>E09 MOVABLE DRIVE FACE ASSY.</p> 
<p>E10 DRIVEN PULLEY ASSY.</p> 	<p>E11 MISSION CASE</p> 	<p>E12 CRANK SHAFT</p> 





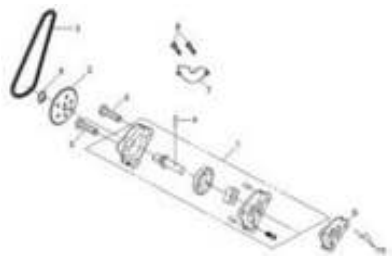
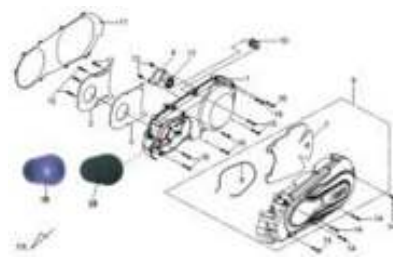
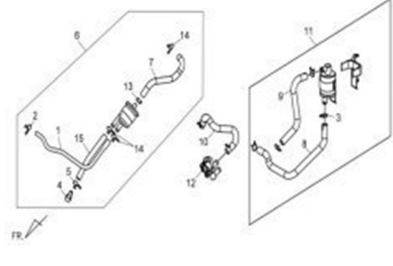

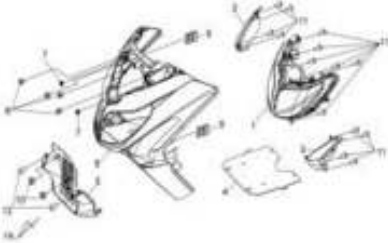

PRICE SHOWN IS PER PIECE. Product image price are approximate guide only.
Prices shown are subject to change without prior notice.

CONTENTS—ENGINE GROUP

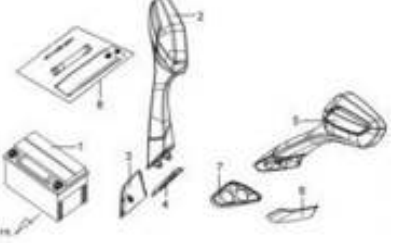
E13 OIL PUMP ASSY.	E14 L. CRANK CASE COVER	E15 BREATHER CHAMBER ASSY.
		

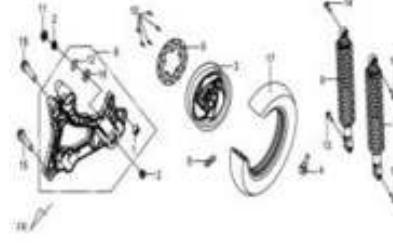
PRICE SHOWN IS PER PIECE. Product image price are approximate guide only.
 Prices shown are subject to change without prior notice.

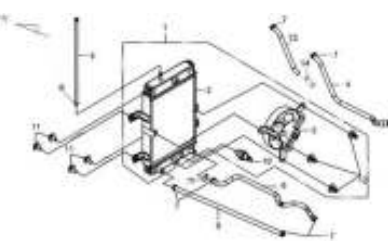
CONTENTS—ENGINE GROUP

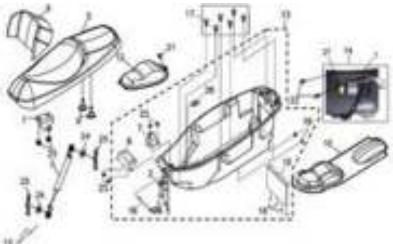
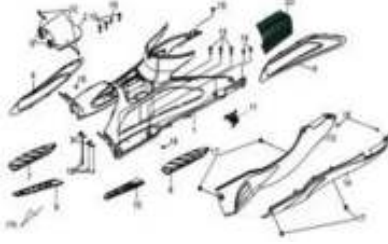
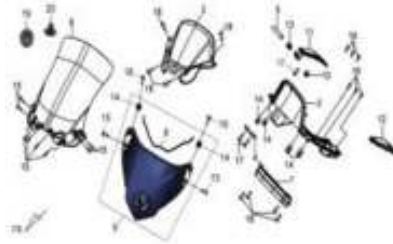
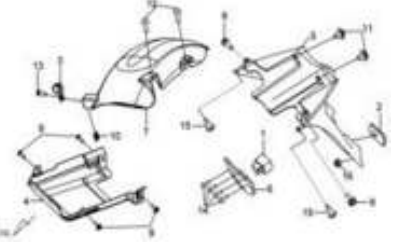
F01 FRONT COVER & HEAD LIGHT	F02 HANDLE & BRAKE ASSY	F03 BACK MIRROR & BATTERY
		
F04 FRONT WHEEL & FORK ASSY	F05 REAR. WHEEL ASSY	F06 INNER BOX & RESERVE TANK
		
F07 RADIATOR ASSY.	F08 BODY COVER & TAIL LIGHT	F09 SEAT & LUGGAGE BOX
		
F10 FLOOR PANEL & SIDE COVER	F11 WIND SCREEN & METER VISOR	F12 RR. FENDER ASSY
		

PRICE SHOWN IS PER PIECE. Product image price are approximate guide only.
 Prices shown are subject to change without prior notice.

CONTENTS—ENGINE GROUP

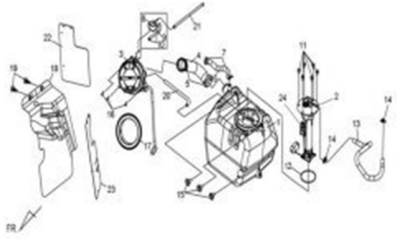
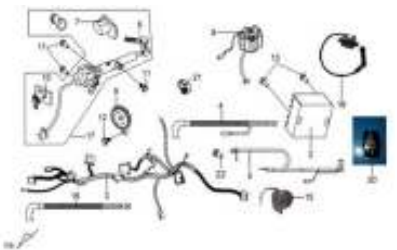
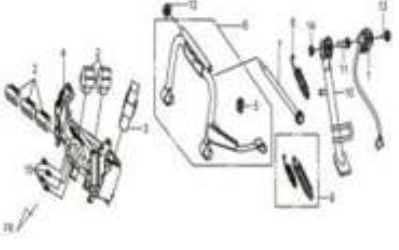
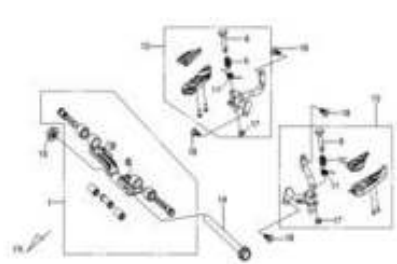
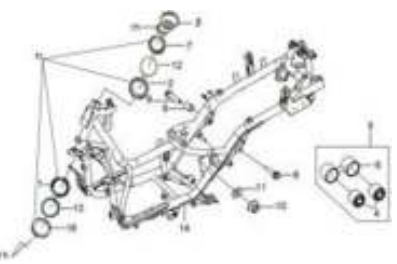
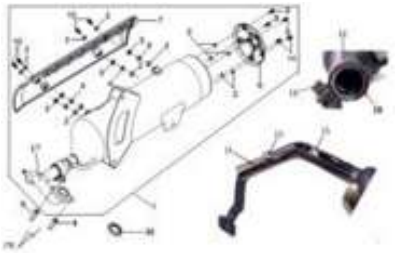
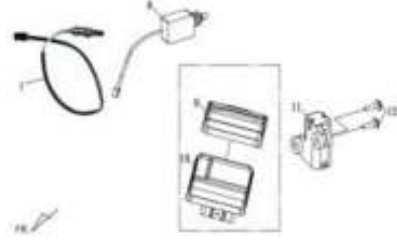
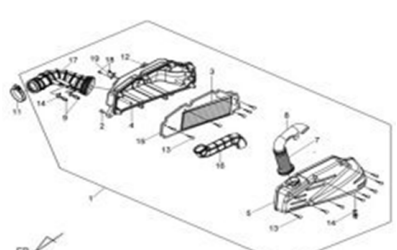
F13 FUEL TANK ASSY	F14 WIRE HARNESS & ELECTRIC PART	F15 MAIN STAND & FR. COVER STAY
		
F16 PILLION STEP	F17 FRAME BODY	F18 MUFFLER ASSY
		
F19 ECU ASSY	F20 AIRCLEANER ASSY	
		

PRICE SHOWN IS PER PIECE. Product image price are approximate guide only.
 Prices shown are subject to change without prior notice.

E01 CYLINDER HEAD COVER

LM25W5-MC(GTS250 EFI CKD TO 馬來西亞)

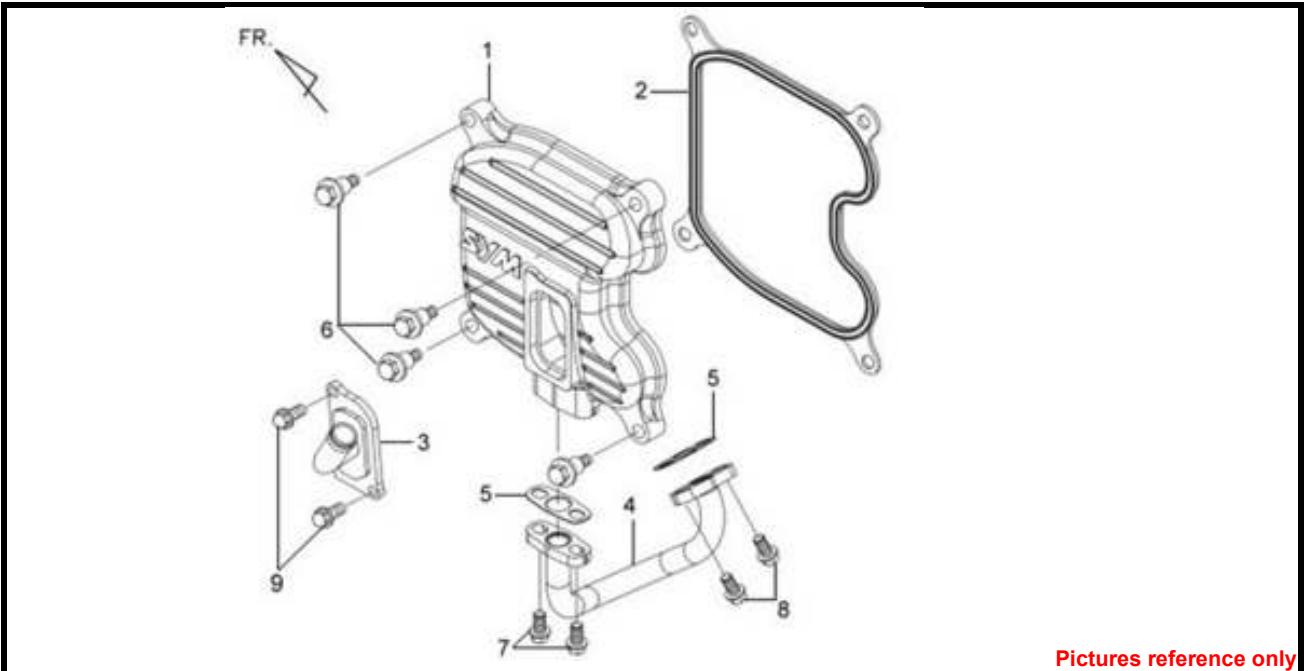

Pictures reference only

PARTS NUMBER	SELLING PRICE (RM/PCS)	DESCRIPTION	QTY	EFFECTIVE DATE
1 12301-HMA-000	89.10	CYLINDER HEAD COVER	1	
2 12391-HMA-000	10.70	CYLINDER HEAD COVER GASKE	1	
3 18610-HKA-000	47.90	REED VALVE COMP	1	
4 18647-HMA-000	36.00	AIR PIPE COMP	1	
5 18654-N14-000	0.80	AIR PIPE GASKET	2	
6 90002-HMA-000	3.30	CYLINDER HEAD COVER BOLT	4	
7 96001-06014-00	0.70	FLANGE BOLT SH 6X14	2	
8 96001-06016-00	0.70	FLANGE BOLT SH 6X16	2	
9 96001-06016-00	0.70	FLANGE BOLT SH 6X16	2	

※ Please check the color & stripe information according to the color index !



※N/A = SUBSTITUTE

※Y = EXCHANGEABLE

※N = NO TEAM WORLDWIDE 2009.08

PRICE SHOWN IS PER PIECE. Product image price are approximate guide only.
Prices shown are subject to change without prior notice.

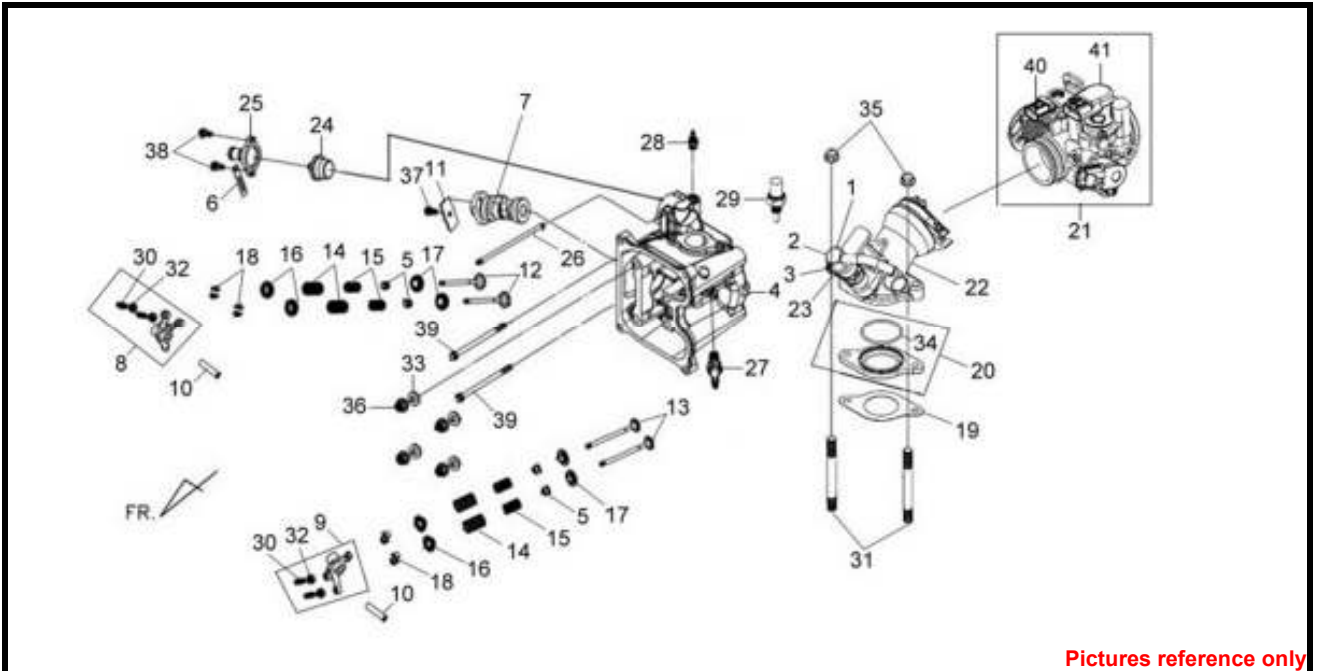

Pictures reference only

PARTS NUMBER	SELLING PRICE (RM/PCS)	DESCRIPTION	QTY	EFFECTIVE DATE	
1 06414-HMC-000	251.90	FUEL INJECTOR	1		
2 06415-A5L-000	5.50	O-RING	1		
3 06416-A5L-000	7.20	SEAL-RING	1		
4 12200-HMC-000	685.50	CYLINDER HEAD COMP	1		
5 12209-H6B-900	6.90	VALVE STEM SEAL	4		
6 12342-X01-000	1.10	CLAMP	1		
7 14100-HML-000	171.40	CAM SHAFT COMP	1		
8 1443A-HMA-000	123.40	IN. VALVE ROCKER ARM ASSY	1		
9 1444A-HMA-000	123.40	EX. VALVE ROCKER ARM ASSY	1		
10 14451-HMA-000	8.60	ROCKER ARM SHAFT	2		
11 14457-HMA-000	1.10	CAM SHAFT SETTING PLATE1.	1		
12 14711-HMA-000	30.80	INLET VALVE	2		
13 14721-HMA-000	49.80	EXHAUST VALVE	2		
13 14721-RFS-000	53.10	EX.VALVE	2	2013/8/1	Y
14 14751-HMA-000	4.10	VALVE OUTER SPRING	4		
15 14761-HMA-000	4.10	INNER VALVE SPRING	4		
16 14771-GB4-680	9.90	SETA INNER VALVE SPRING	4		
17 14777-KN7-670	5.20	VALVE SPRING SEAT	4		
18 14781-M9Q-000-A	9.80	VALVE COTTER SET(1SET/4PCS)	8		
19 16201-HMC-000	1.00	CARB. INSULATOR GASKET	1		
20 1621A-HMC-000	9.30	CARBURETOR INSULATOR ASSY	1		
21 16401-HWA-000	548.40	THROTTLE BODY ASSY	1		
22 1711A-HMC-000	87.50	INLET PIPE ASSY	1		

PRICE SHOWN IS PER PIECE. Product image price are approximate guide only.
 Prices shown are subject to change without prior notice.

23	17120-HMC-000	92.50	FUEL INJECTOR CUP	1
24	19300-HMA-000	72.10	THERMOSTAT ASSY.	1
25	19315-KJ9-000	10.70	THERMOSTAT COVER	1
26	1951A-HMA-000	10.00	THERMOSTAT TUBE ASSY.	1
27	AC-005-1201-0009	16.50	PLUG CR8E	1
28	37750-PC1-004	45.10	THERMO UNIT ASSY	1
29	37880-HMC-000	44.60	TW SENSOR	1
30	90012-HLK-000	5.20	TAPPET ADJUSTING SCREW	4
31	90032-HMA-000	8.90	CYLINDER STUD BOLT B	2
32	90206-HLK-000	3.30	TAPPET ADJUSTING NUT	4
33	90442-HMA-000	1.00	SEAL WASHER	4
34	91308-HMA-000	2.50	O-RING 34*2.0	1
35	94050-06000	0.40	FLANGE NUT 6MM	2
36	94050-10080	1.70	FLANGE NUT 10MM	4
37	96001-06014-00	0.70	FLANGE BOLT SH 6X14	1
38	96001-06016-00	0.70	FLANGE BOLT SH 6X16	2
39	96001-06090-00	1.30	FLANGE SH BOLT 6X90	2
40	1614-906-0002	277.60	MAP SENSOR (16401-HML-000)	1
41	4000-452-0003	569.10	ISC VALVE	1

※ Please check the color & stripe information according to the color index !



※N/A = SUBSTITUTE

※Y = EXCHANGEABLE

※N = NOT

TEAMWORLD IND. 2009.08

PRICE SHOWN IS PER PIECE. Product image price are approximate guide only.
Prices shown are subject to change without prior notice.

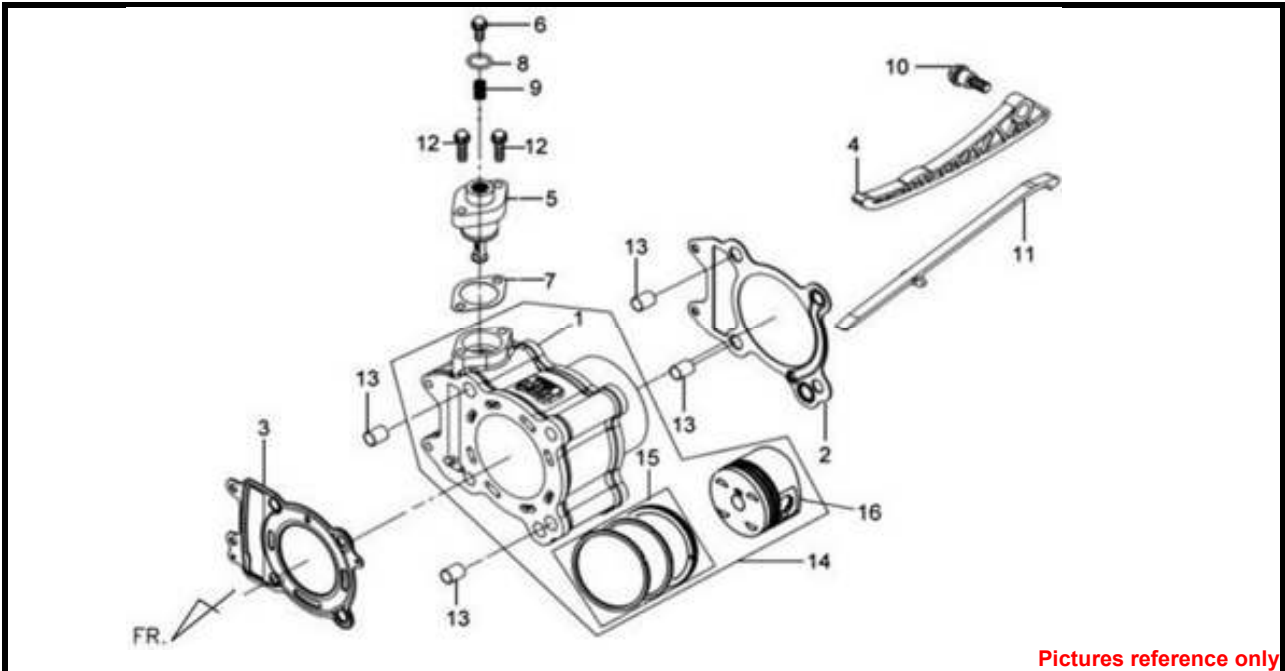

PARTS NUMBER	SELLING PRICE (RM/PCS)	DESCRIPTION	QTY	EFFECTIVE DATE
1 12100-HMA-000	511.20	CYLINDER COMP	1	
2 12191-HMA-000	4.30	CYLINDER GASKET	1	
3 12251-HMA-000	41.10	CYLINDER HEAD GASKET	1	
4 14510-RFA-000	9.60	CAM CHAIN TENSIONER	1	
5 14520-H6T-000	44.60	TENSIONER LIFTER	1	
6 14522-H6T-000	2.80	TENSIONER ADJUSTER BOLT	1	
7 14523-M9Q-000	1.70	TENSIONER LIFTER GASKET	1	
8 14524-H6T-000	1.70	OIL-RING	1	
9 14525-H6T-000	2.50	ADJUSTER SPRING	1	
10 14531-KJ9-000	2.50	CAM CHAIN TENSIONERPIVOT	1	
11 14610-RFA-000	15.40	CAM CHAIN GUIDE	1	
12 90001-M9Q-000	0.80	FLANGE SHF BOLT 6X22	2	
13 94301-12200	2.50	DOWEL PIN 12*20	4	
14 12100-HMA-000-A	633.50	CYLINDER SET	1	
15 13010-HMA-000	61.70	PISTON RING SET	1	
16 13101-HMA-000	58.30	PISTON	1	

※ Please check the color & stripe information according to the color index !

※N/A = SUBSTITUTE

※Y = EXCHANGEABLE

※N = NOT AVAILABLE



TEAM WORLD LTD. 2009.08

E04 CYLINDER HEAD SIDE COVER

LM25W5-MC(GTS250 EFI CKD TO 馬來西亞)

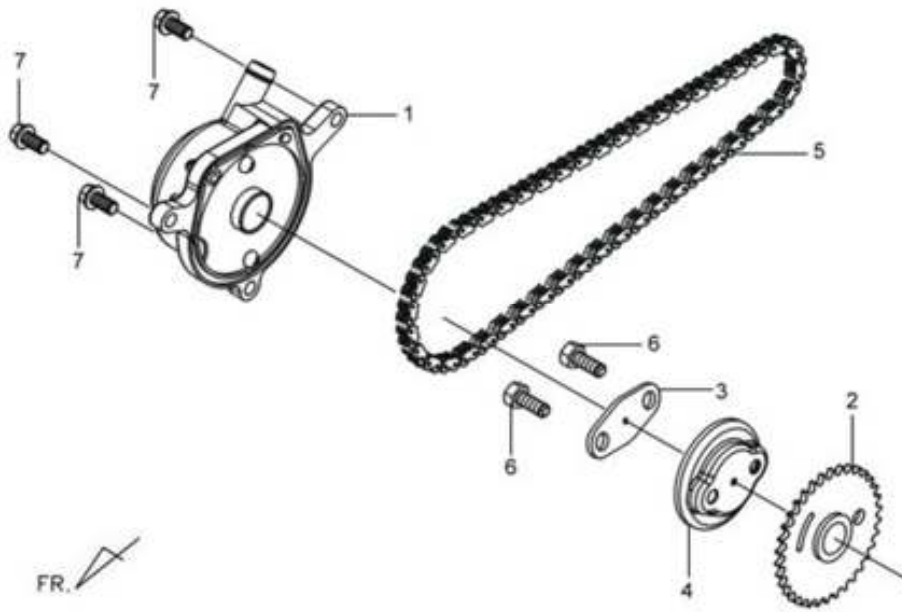

Pictures reference only

PARTS NUMBER		SELLING PRICE (RM/PCS)	DESCRIPTION	QTY	EFFECTIVE DATE
1	1231A-HMA-000	46.30	CYLINDER HEAD COVER ASSY	1	
1-1	91301-HMA-000	4.10	HEAD SIDE COVER O-RING	1	
2	14105-RFA-000	30.30	CAM SPROCKET	1	
3	14105-X01-000	2.80	CAM SPROCKET WASHER	1	
4	14108-M36-000	2.80	CENTRIFUGAL DISK	1	
5	1C14401-RFA-000	120.00	CAM CHAIN 92RH2010-100L	1	
6	92101-06016-0H	1.00	HEX BOLT 6*16	2	
7	96001-06018-00	0.80	FLANGE BOLT SH 6X18	3	

※ Please check the color & stripe information according to the color index !

※N/A = SUBSTITUTE

※Y = EXCHANGEABLE

※N = NOT



TEAM WORLD LTD. 2009.08

PRICE SHOWN IS PER PIECE. Product image price are approximate guide only.
Prices shown are subject to change without prior notice.

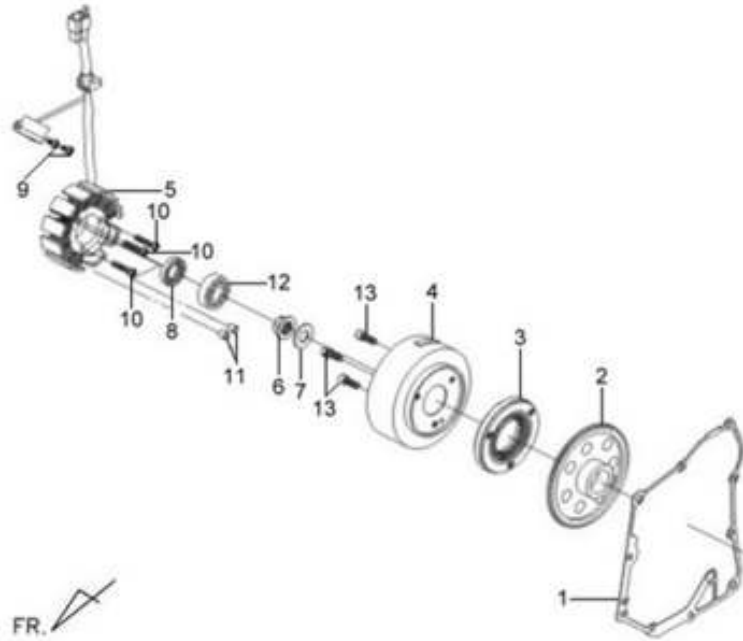

Pictures reference only

PARTS NUMBER	SELLING PRICE (RM/PCS)	DESCRIPTION	QTY	EFFECTIVE DATE
1 11394-HMA-002	10.60	R. CRANK CASE COVER GASKET	1	
2 28110-HMA-000	105.70	STARTING CLUTCH GEAR COMP	1	
3 2812A-HMA-000	531.40	ONE WAY CLUTCH ASSY	1	
4 31110-HMC-000	219.40	FLYWHEEL COMP	1	
5 31120-HMC-000	248.50	STATOR COMP	1	
6 90201-KR8-751-M1	4.80	FLANGE NUT 14MM	1	
7 90401-KJ9-000	2.80	THRUST WASHER 14X28X2	1	
8 91202-HMA-000	3.80	OIL SEAL	1	
9 93500-05016-0A	0.80	PAN SCREW 5X16	2	
11 94301-08140	1.00	DOWEL PIN 8X14	2	
12 96140-62013-10	14.40	RADIAL BALL BRG. 6201LUC3	1	
13 90157-F3G-000	1.70	SOCKET BOLT 8X20	3	

※ Please check the color & stripe information according to the color index !

※N/A = SUBSTITUTE

※Y = EXCHANGEABLE

※N = NOT



TEAM WORLD BLD. 2009.08

PRICE SHOWN IS PER PIECE. Product image price are approximate guide only.
Prices shown are subject to change without prior notice.

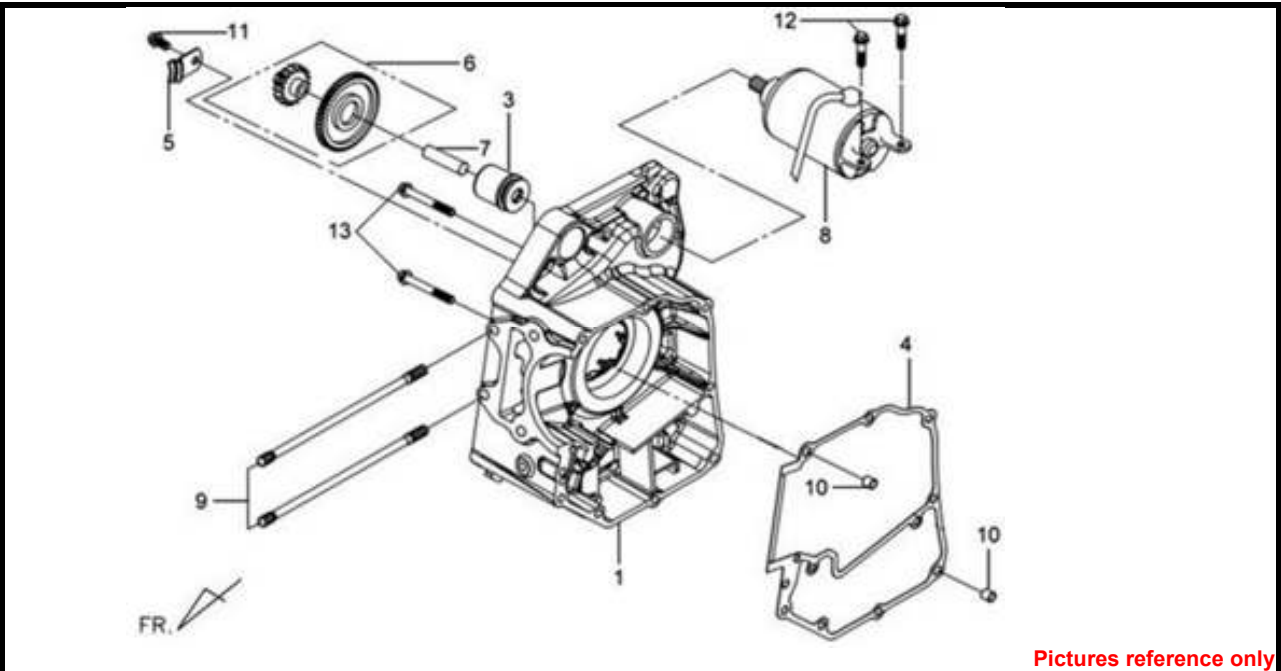

PARTS NUMBER	SELLING PRICE (RM/PCS)	DESCRIPTION	QTY	EFFECTIVE DATE	
1 11100-HMA-001	342.00	R. CRANK CASE COMP	1		
3 11120-LEA-000	44.50	ENG. HANGER BUSH ASSY	1		
4 11191-HMA-000	5.00	CRANK CASE GASKET	1		
5 14151-RFA-000	2.00	CAM CHAIN SETTING PLATE	1		
6 28100-HMA-000	58.30	STARER RED.GEAR COMP	1		
7 28102-HMA-000	5.80	START.REDUCTION GEAR SHAFT	1		
8 31200-HMA-000	359.90	START MOTOR ASSY.	1		
8 31200-HMA-100	359.90	START MOTOR ASSY	1	2013/4/22	N
9 90031-HMA-000	9.60	CYLINDER STUD BOLT A	2		
10 94301-08140	1.00	DOWEL PIN 8X14	2		
11 96001-06010-08	0.80	FLANGE BOLT SH 6X10	1		
11 96001-06012-08	0.80	FLANGE BOLT SH 6X10	1	2010/1/6	N
12 96001-06022-00	1.00	FLANGE BOLT SH 6X22	2		
13 96001-06055-00	1.70	BOLT FLANGE SH 6X55	2		

※ Please check the color & stripe information according to the color index !

※N/A = SUBSTITUTE

※Y = EXCHANGEABLE

※N = NOT AVAILABLE



TEANWORLD 2009.08

PRICE SHOWN IS PER PIECE. Product image price are approximate guide only.
Prices shown are subject to change without prior notice.

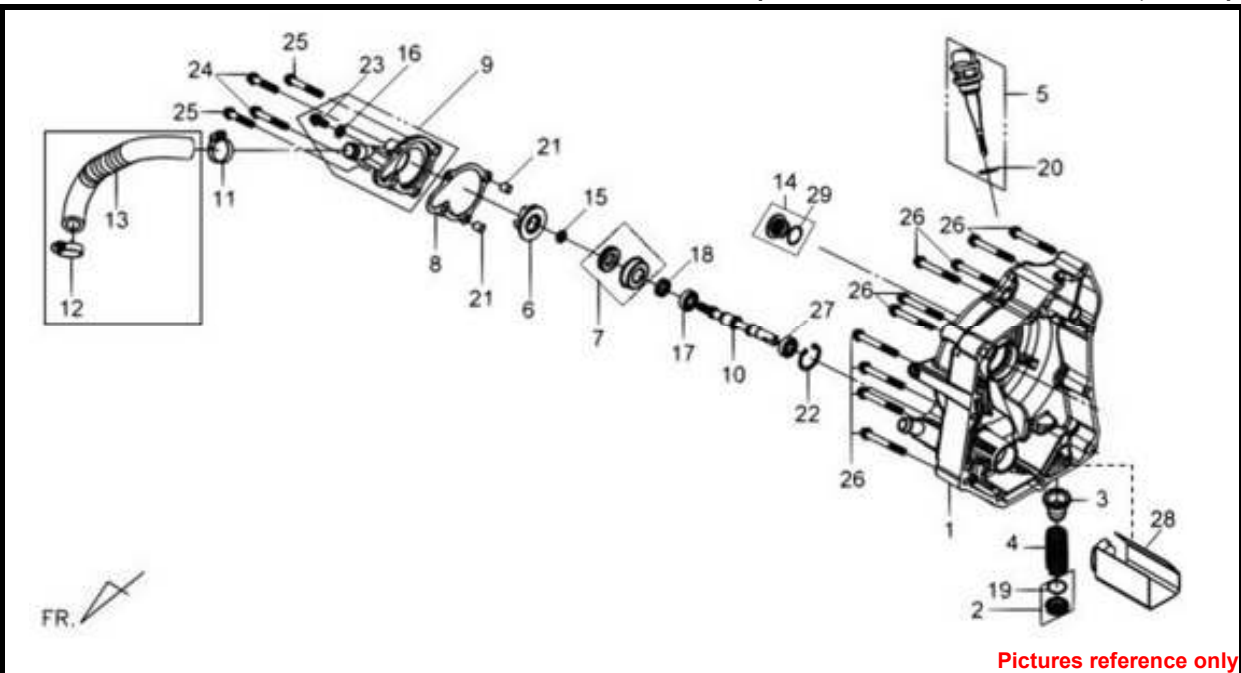

PARTS NUMBER	SELLING PRICE (RM/PCS)	DESCRIPTION	QTY	EFFECTIVE DATE	
1 11330-HMA-000	278.20	R. CASE CRANK COVER COMP	1		
1 11330-LEA-000	411.40	R. CASE CRANK COVER COMP	1	2009/6/2	N
2 1236A-V02-000	8.00	TAPPET ADJ HOLE CAP ASSY	1		
3 15421-107-000	5.10	OIL FILTER SCREN	1		
3 15421-B9D-000	4.80	OIL FILTER SCREN	1	2011/7/27	
4 15426-GE1-920	1.30	OIL FILTER SCREWS PG.	1		
5 1565A-HMA-000	4.10	OIL LEVEL GAUGE ASSY	1		
6 19215-HLA-000	10.20	WATER PUMP IMPELLER	1		
7 19217-H9A-300	24.00	MECHANICAL SEAL	1		
8 19229-H9A-000	1.30	WATER PUMP GASKET	1		
9 1922A-HMA-000	25.60	WATER PUMP COVER ASSY	1		
9 1922A-LEA-000	29.10	WATER PUMP COVER ASSY.	1	2010/3/9	N
10 19231-HMA-000	30.80	WATER PUMP SHAFT	1		
11 19505-KS6-700	3.30	WATER HOSE CLAMP A	1		
12 1950A-HMA-000	14.40	WATER HOSE ASSY	1		
13 19604-H01-000	4.80	LH. WATER HOSE GUARD WIRE	1		
14 9008A-H9A-000	4.10	A.C.G. CAP ASSY 14MM	1		
15 90423-KJ9-000	0.80	WASHER 7.2X13X1.2	1		
16 90478-700-000	0.80	WASHER A. 6MM	1		
17 91001-KJ9-005	17.10	RADIAL BALL BRG.6901	1		
18 91205-KF0-003	4.10	OIL SEAL 12X20X5	1		
19 91302-M9Q-000	1.70	O-RING 30.8MM	1		
20 91307-035-000	1.40	O-RING 18X3	1		

PRICE SHOWN IS PER PIECE. Product image price are approximate guide only.
Prices shown are subject to change without prior notice.

21	94301-08140	1.00	DOWEL PIN 8X14	2
22	94520-26000	1.30	CIRCLIP IN 26MM	1
23	96001-06010-00	0.80	SH FLANGE BOLT 6X10	1
24	96001-06022-00	1.00	FLANGE BOLT SH 6X22	2
25	96001-06032-00	1.00	FLANGE BOLT SH 6X32	2
26	96001-06045-00	1.00	FLANGE BOLT 6X45	10
27	96100-60000-00	15.00	RADIAL BALL BRG. 6000CM	1
28	11107-HMA-000	7.60	MAGNET PLATE	1
29	91303-377-000	1.00	O-RING	1

※ Please check the color & stripe information according to the color index !



※N/A = SUBSTITUTE

※Y = EXCHANGEABLE

※N = NOT AVAILABLE

TEAMWORK INC. 2009.08

PRICE SHOWN IS PER PIECE. Product image price are approximate guide only.
Prices shown are subject to change without prior notice.

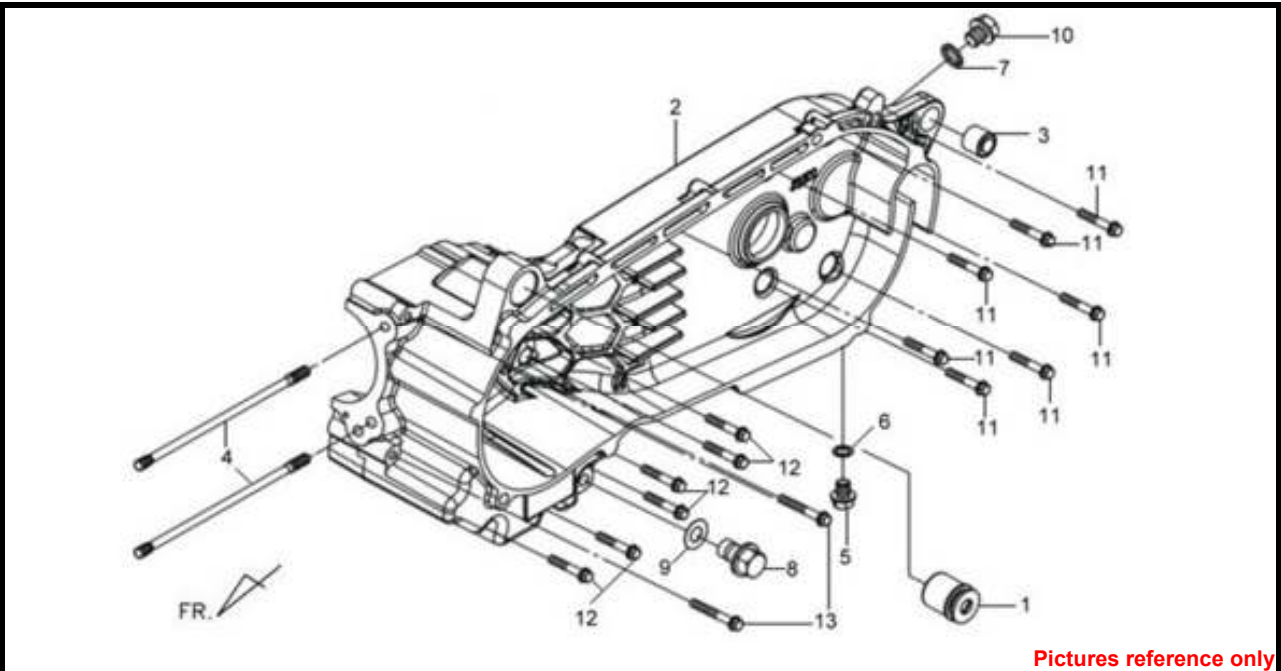

PARTS NUMBER	SELLING PRICE (RM/PCS)	DESCRIPTION	QTY	EFFECTIVE DATE
1 11120-LEA-000	44.50	ENG. HANGER BUSH ASSY	1	
2 11200-HMA-000	527.90	L CRANK CASE COMP	1	
3 11203-GC7-300	3.80	RR.CUSHION RUBBER BUSH	1	
4 90032-HMA-000	8.90	CYLINDER STUD BOLT B	2	
5 90103-M9Q-000	1.00	SPECIAL BOLT 8MM	1	
6 90474-M9Q-000	0.40	WASHER 8X17	1	
7 90481-M9Q-000	0.80	PLAIN WASHER 10.2MM	1	
7 90481-M9Q-100	0.80	PLAIN WASHER 10.2MM	1	2012/6/11
8 92800-12000	2.60	DRAIN PLUG BOLT 12MM	1	
9 94109-12000	1.00	DRAIN PLUG WASHER 12MM	1	
10 95701-10012-08	1.70	FLANGE BOLT 10X12	1	
11 95801-08050-08	2.50	FLANGE BOLT 8*50	7	
12 96001-06050-00	0.80	FLANGE BOLT SH 6X50	6	
13 96001-06070-00	1.30	FLANGE SH BOLT 6X70	2	

※ Please check the color & stripe information according to the color index !

※N/A = SUBSTITUTE

※Y = EXCHANGEABLE

※N = NOT AVAILABLE
 TEAMWORLD PTD. 2009.08

PRICE SHOWN IS PER PIECE. Product image price are approximate guide only.
 Prices shown are subject to change without prior notice.

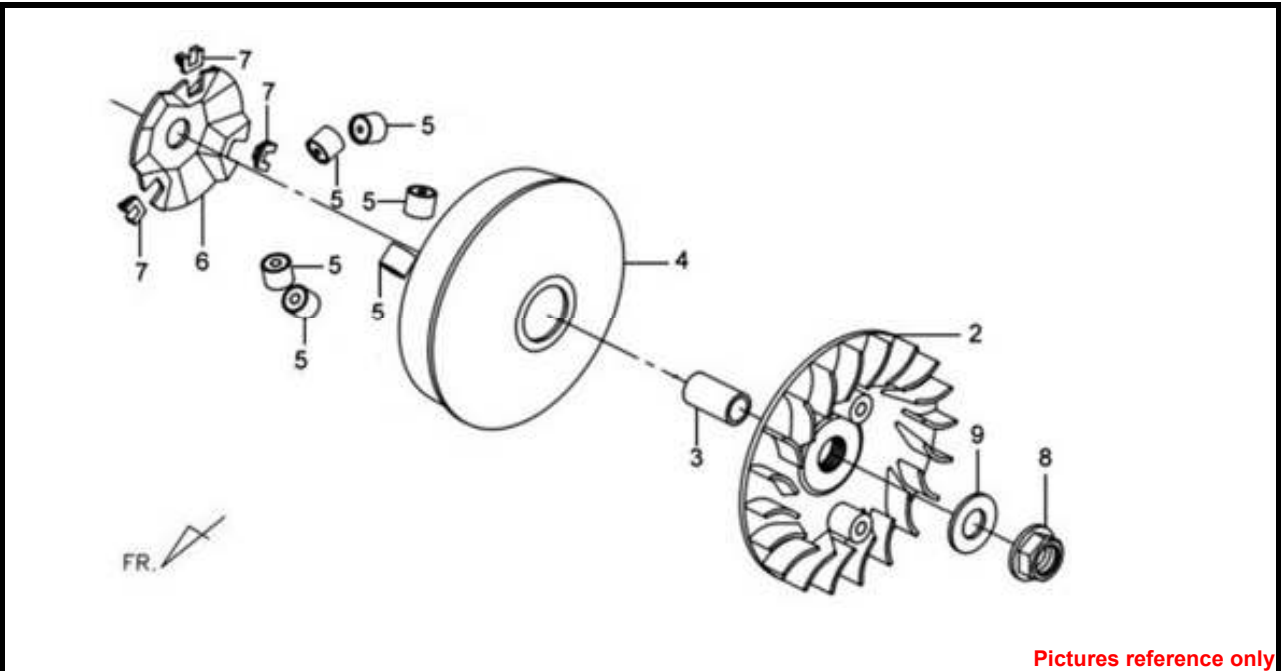

Pictures reference only

PARTS NUMBER	SELLING PRICE (RM/PCS)	DESCRIPTION	QTY	EFFECTIVE DATE
2 22102-HMA-000	81.10	DRIVE FACE	1	
3 22105-HMA-000	41.10	DRIVE FACE BOSS	1	
4 22110-HMA-000	132.00	MOVABLE DRIVE FACE COMP	1	
5 22121-RB1-001-A	68.50	WEIGHT ROLLER COMP(6PCS)(18G)	1	
6 22131-HMA-000	36.00	RAMP PLATE	1	
7 22132-HMA-000-A	6.10	SLIDE PIECE SET	1	
8 90201-KR8-751-M1	4.80	FLANGE NUT 14MM	1	
9 90401-KJ9-000	2.80	THRUST WASHER 14X28X2	1	

※ Please check the color & stripe information according to the color index !



※N/A = SUBSTITUTE

※Y = EXCHANGEABLE

※N = NOT AVAILABLE

TEAM WORLD LTD. 2009.08

E10 DRIVEN PULLEY ASSY.

LM25W5-MC(GTS250 EFI CKD TO 馬來西亞)

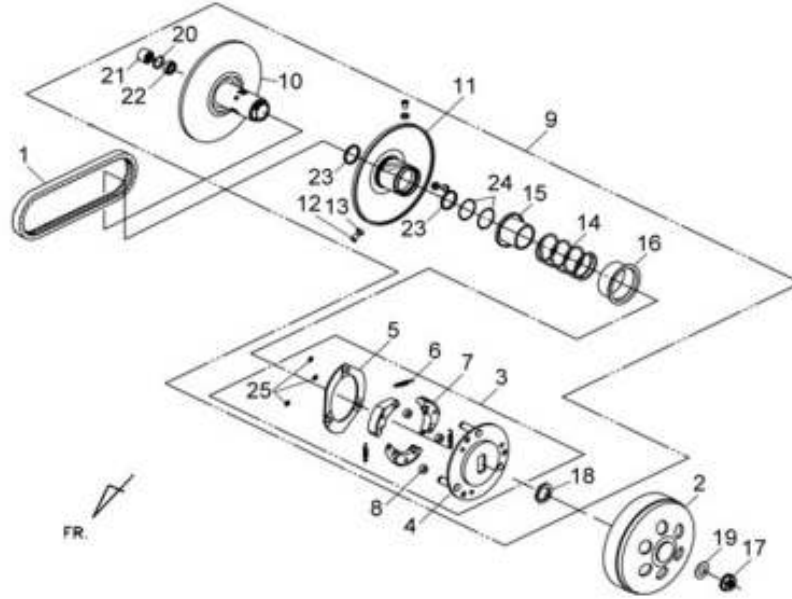

PARTS NUMBER	SELLING PRICE (RM/PCS)	DESCRIPTION	QTY	EFFECTIVE DATE	
1 1B01HMA01	247.90	DRIVE BELT(924X24.4X30)	1		
2 22101-HMA-000	130.20	CLUTCH OUTER	1		
3 22300-HMB-000	253.70	DRIVE PLATE ASSY.	1		
3 22300-L3D-000	291.40	DRIVE PLATE ASSY	1	2013/4/15	N
4 22350-HMA-000	47.90	DRIVE PLATE COMP.	1		
5 22361-HMA-000	10.70	CLUTCH SIDE PLATE	1		
6 22401-HMA-000	4.10	CLUTCH SPRING	3		
7 22530-HMB-000-A	205.60	CLUTCH WEIGHT(3PCS)	1		
8 22804-HMA-000	4.50	CLUTCH DAMPER RUBBER	3		
9 23010-HMB-000	685.50	DRIVE PULLEY ASSY	1		
9 23010-L2A-000	862.00	DRIVEN PULLEY ASSY	1	2013/4/15	N
10 23200-HMA-000	318.70	DRIVEN FACE ASSY	1		
11 23220-HMA-000	212.60	MOVABLE DRIVEN FACE COMP	1		
12 23225-HMA-000	3.80	ROLLER GUIDE PIN	3		
13 23226-HMA-000	2.50	GUIDE ROLLER	3		
14 23233-HMA-000	20.60	DRIVEN FACE SPRING	1		
15 23237-HMA-000	15.40	SEAL COLLER	1		
16 23238-HMA-000	10.90	SPRING COLLAR	1		
17 90201-KR8-751-M1	4.80	FLANGE NUT 14MM	1		
18 90202-HMA-000	9.60	SPECIAL NUT	1		
19 90401-KJ9-000	2.80	THRUST WASHER 14X28X2	1		
20 90602-HMA-000	4.10	IN. CIRCLE CLIP	1		
21 91006-HMA-300	68.50	NEEDLE BREAING	1		
22 91007-HMA-300	24.00	RADIAL BALL BRG.	1		

PRICE SHOWN IS PER PIECE. Product image price are approximate guide only.
 Prices shown are subject to change without prior notice.

23	91211-HMA-000	3.80	OIL SEAL	2		
24	91305-HMA-000	3.10	O-RING 47*2.0	2		
25	94540-08010	0.80	E-RING	3		

PRICE SHOWN IS PER PIECE. Product image price are approximate guide only.
Prices shown are subject to change without prior notice.

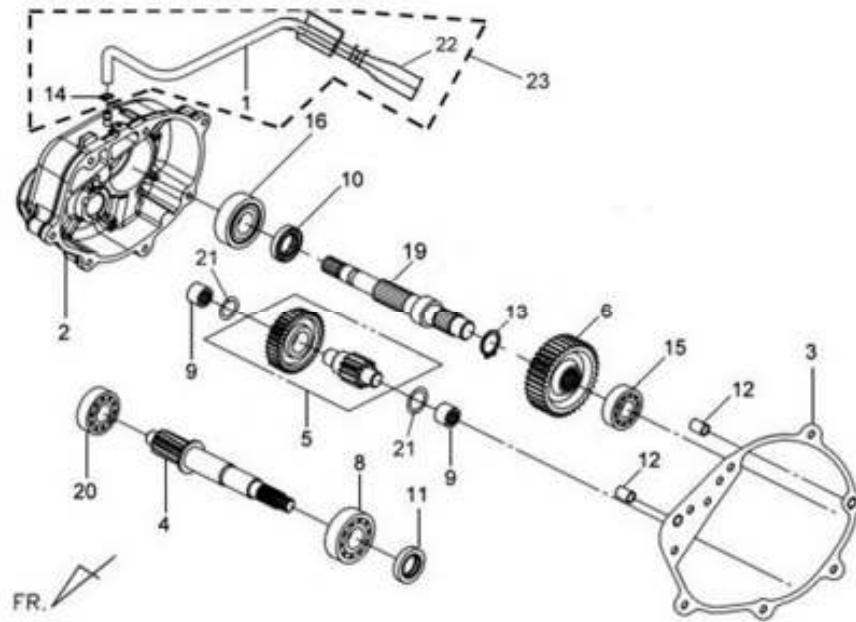

Pictures reference only

PARTS NUMBER	SELLING PRICE (RM/PCS)	DESCRIPTION	QTY	EFFECTIVE DATE
1 11221-HMA-000	3.30	MISSION BREATHER TUBE	1	
2 21200-HMA-000	181.60	MISSION CASE COMP	1	
3 21395-HMA-000	6.90	MISSION COVER GASKET	1	
4 23411-HMA-000	99.40	DRIVE SHAFT	1	
5 23420-HMA-000	90.80	COUNTER SHAFT COMP	1	
6 23432-HMA-000	92.50	FINAL GEAR	1	
8 91009-HMC-000	37.70	BALL RADIAL BRG.CSB205 JR2C3	1	
9 91002-HMA-000	24.00	NEEDLE BRG.	2	
10 91203-HMA-000	3.80	OIL SEAL	1	
11 91204-HMA-000	9.60	OIL SEAL	1	
12 94301-08140	1.00	DOWEL PIN 8X14	2	
13 94510-25000	1.30	EX. CIR CLIP	1	
14 95002-02080	0.80	BREATHER TUBE CLIP B8	1	
15 96100-62040-10	16.20	RADIAL BALL BRG. 6204	1	
16 96150-62050-10	27.50	RADIAL BALL BRG. 6205LLU	1	
17 23421-HMA-300	35.60	COUNTER SHAFT	1	
18 23422-HMA-300	77.50	COUNTER GAER	1	
19 23431-HMA-000	123.40	FINAL SHAFT	1	
20 96100-63020-00	17.10	RAD.BALL.BRG.6302	1	
21 90401-HMA-000	2.80	THRUST WASHER 15MM	2	
22 5520A-KBN-900	6.90	OIL STRN. JOINT ASSY	1	
23 1122A-HMA-000	10.70	MISSION BREATHER TUBE ASSY	1	

※ Please check the color & stripe information according to the color index !



PRICE SHOWN IS PER PIECE. Product image price are approximate guide only.
Prices shown are subject to change without prior notice.

E12 CRANK SHAFT

LM25W5-MC(GTS250 EFI CKD TO 馬來西亞)

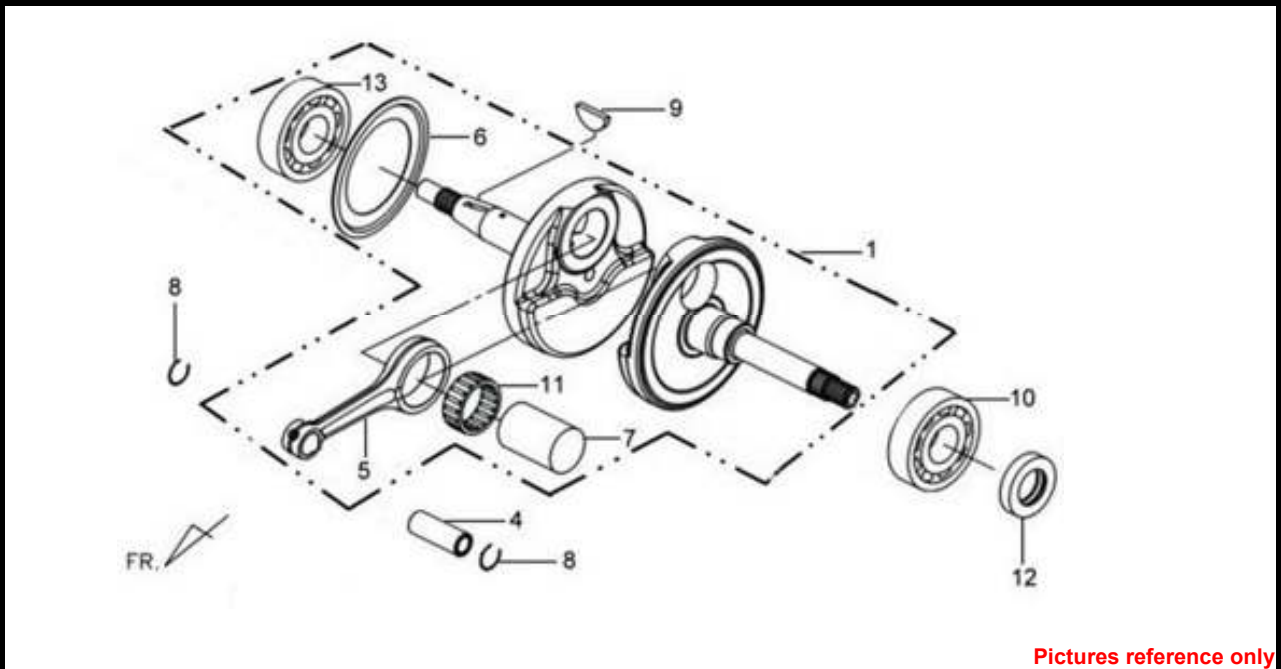

Pictures reference only

PARTS NUMBER	SELLING PRICE (RM/PCS)	DESCRIPTION	QTY	EFFECTIVE DATE
1 13000-HML-010	651.30	CRANK SHAFT COMP	1	
4 13111-HMA-000	14.40	PISION PIN	1	
5 13201-LEA-000	126.80	CONNECTING ROD	1	
6 13371-HMA-300	3.10	R CRANK SIDE PLATE	1	
7 13381-HMA-300	27.50	CRANK PIN	1	
8 90601-HMA-000	0.80	PISTON PIN CLIP	2	
9 90701-HB6-010	4.80	WOODRUFF KEY 25X14X4	1	
10 91001-HMA-000	110.20	RADIAL BALL BRG. TMB306	1	
11 91003-HML-000	109.80	CONN. ROD BRG. KU32*41*17.8	1	
11 91003-LEA-000	109.80	CONN. ROD BRG. KU32*41*17.8	1	
12 91201-HMA-300	4.80	OIL SEAL	1	
13 96100-62070-10	39.40	RADIAL BALL BEARING. 6207	1	

※ Please check the color & stripe information according to the color index !



※N/A = SUBSTITUTE

※Y = EXCHANGEABLE

※N = NOT AVAILABLE

TEAN WORLD Sdn. Bhd. 2009.08

PRICE SHOWN IS PER PIECE. Product image price are approximate guide only.
Prices shown are subject to change without prior notice.

E13 OIL PUMP ASSY.

LM25W5-MC(GTS250 EFI CKD TO 馬來西亞)

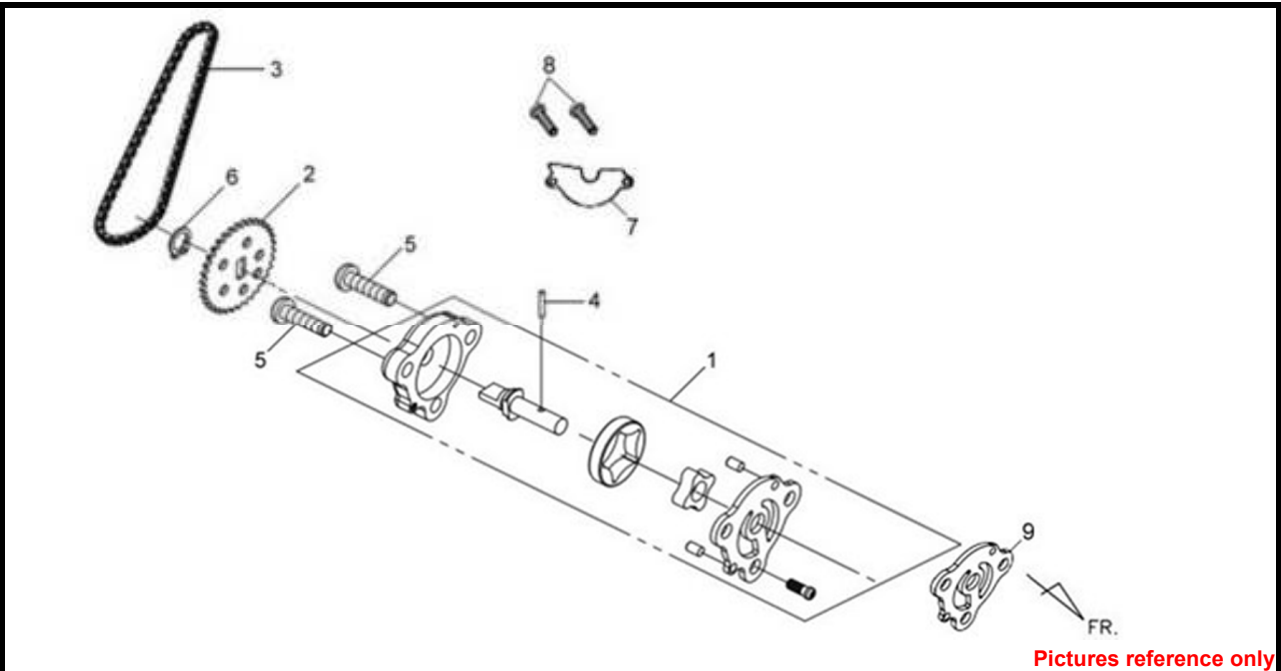

Pictures reference only

PARTS NUMBER		SELLING PRICE (RM/PCS)	DESCRIPTION	QTY	EFFECTIVE DATE
1	15100-HMA-000	42.90	OIL PUMP ASSY.	1	
2	15133-HMA-000	15.30	OIL PUMP DRIVEN SPROCKET	1	
3	1C15141-HMA-000	37.70	OIL PUMP CHAIN 92RH2005-48	1	
4	91101-HMA-000	1.70	PIN 2.5*11.8	1	
5	93500-06025-0H	0.40	PAN SCREW	1	
6	94510-10000	0.80	CIR CLIP 10MM	1	
7	15711-HML-000	3.30	OIL SEPARATER	1	
8	96001-06010-08	0.80	FLANGE BOLT SH 6X10	2	
9	15126-B8A-000	1.70	OIL PUMP GASKET	1	

※ Please check the color & stripe information according to the color index !



※N/A = SUBSTITUTE

※Y = EXCHANGEABLE

※N = NOT AVAILABLE

TEAM WORLD BOND. 2009.08

PRICE SHOWN IS PER PIECE. Product image price are approximate guide only.
Prices shown are subject to change without prior notice.

E14 L. CRANK CASE COVER

LM25W5-MC(GTS250 EFI CKD TO 馬來西亞)

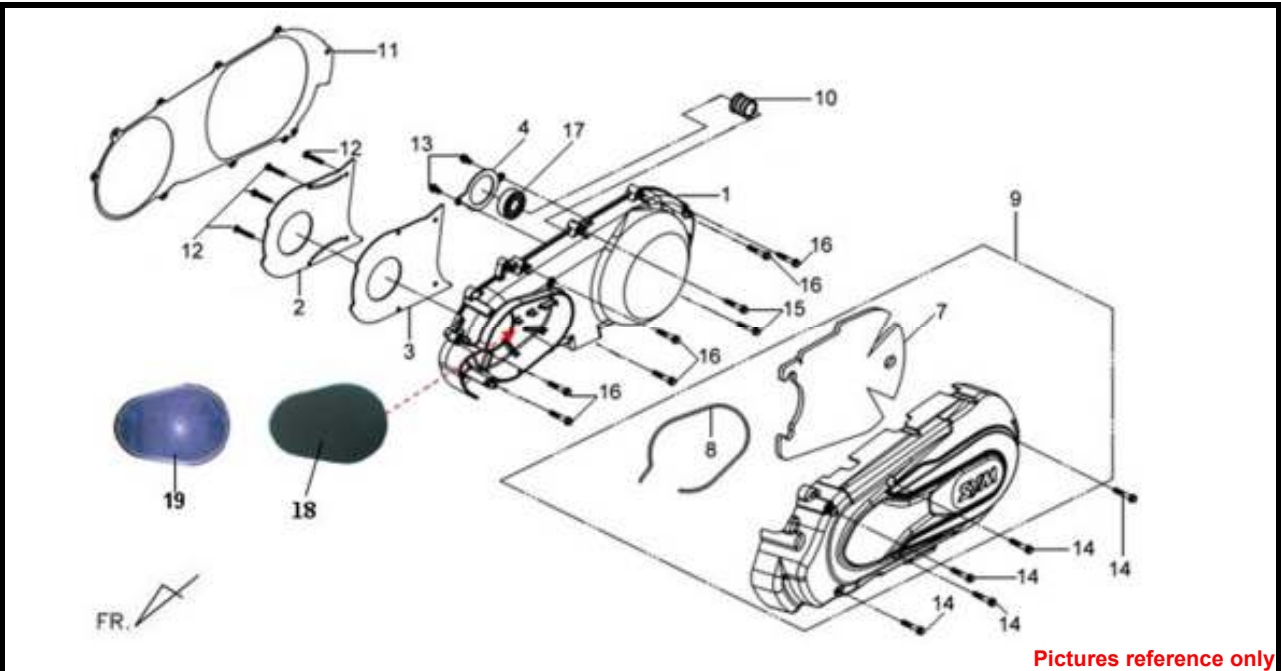

PARTS NUMBER	SELLING PRICE (RM/PCS)	DESCRIPTION	QTY	EFFECTIVE DATE
1 11341-HMA-000	274.20	L. CASE COVER	1	
2 11342-HMA-000	8.30	L. CASE COVER PLATE	1	
3 11343-HMA-000	3.50	L. CASE COVER PLATE GASKET	1	
4 11346-HMA-000	3.50	L. BEARING SETTING PLATE	1	
7 11352-HMA-000	18.00	L. OUTER COVER SPONGE	1	
8 11353-HMA-000	3.50	L. OUTER COVER SEAL	1	
9 1135A-HMA-000-KB	260.60	L OUTER COVER ASSY.BK-001U/BK-001C	1	
10 1137A-HMA-000	44.60	BERING STAY COLLAR ASSY	1	
11 11395-HMA-000	12.70	L. CRANK CASE COVER GASKET	1	
12 93500-05012-0H	0.80	PAN SCREW 5X12	4	
13 96001-06012-00	0.80	FLANGE BOLT SH 6X12	1	
14 96001-06018-07	0.80	SH. FLANGE BOLT	5	
15 96001-06030-00	1.30	FLANGE BOLT SH 6X30	2	
16 96001-06035-00	1.30	FLANGE SH BOLT 6X35	6	
17 96150-60060-10	39.40	RADIAL BALL BEARING 6006LLU	1	
18 11344-HMA-000	9.00	L. SIDE CVOER ELEMENT	1	
19 17221-LEA-000	45.90	TRAP COMP.	1	

※ Please check the color & stripe information according to the color index !

※N/A = SUBSTITUTE

※Y = EXCHANGEABLE

※N = NOT AVAILABLE



TEAM WORLD BROS. 2009.08

PRICE SHOWN IS PER PIECE. Product image price are approximate guide only.
Prices shown are subject to change without prior notice.

E15 BREATHER CHAMBER ASSY.

LM25W5-MC(GTS250 EFI CKD TO 馬來西亞)

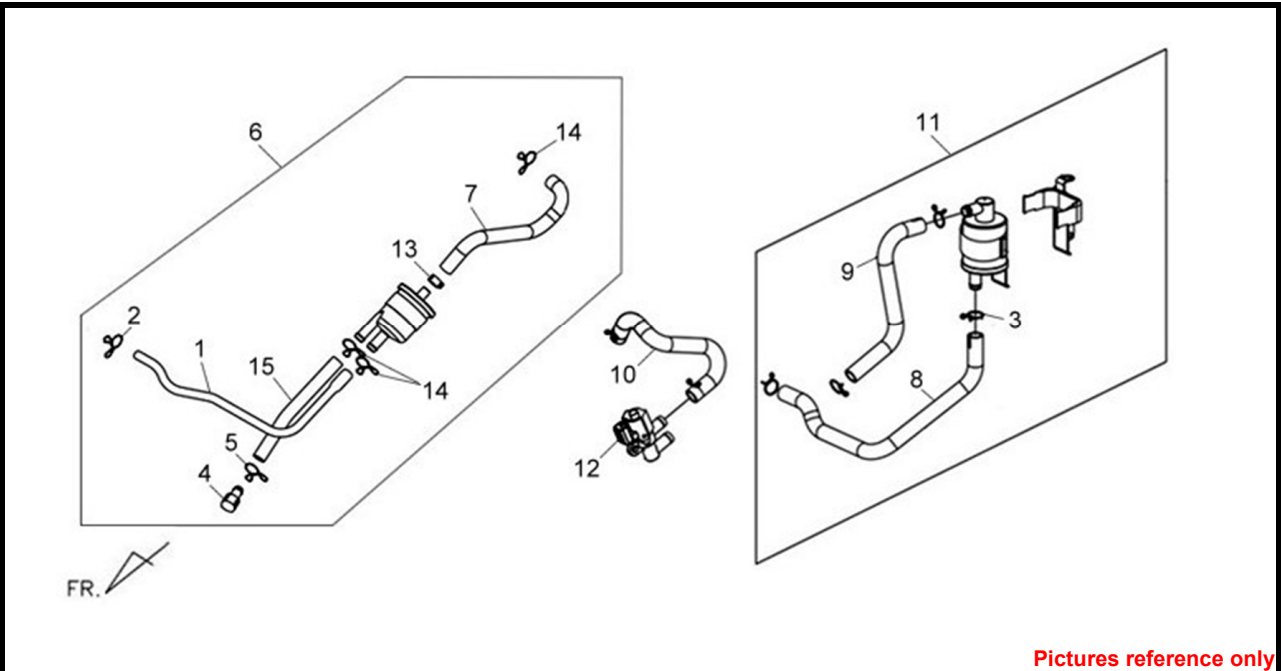

Pictures reference only

PARTS NUMBER	SELLING PRICE (RM/PCS)	DESCRIPTION	QTY	EFFECTIVE DATE
1 11211-HMA-000	19.80	BREATHER TUBE	1	
2 15772-500-013	2.80	BREATHER TUBE CLIP	1	
3 17369-KB4-670	2.50	TUBE CLIP	2	
4 17370-M9Q-000	3.30	PLUG,BREATHER TUBE.	1	
5 17371-M9Q-000	0.80	BREATHER TUBE CLIP	1	
6 1738A-HMB-000	42.90	BREATHER CHAMPER ASSY	1	
7 17562-HMA-000	9.60	P.C.V./A.C. TUBE	1	
8 17571-HMC-000	17.10	A.I.C.V. TUBE A	1	
9 17574-HMC-000	17.10	A.I.C.V. TUBE B	1	
10 17576-HMC-000	12.10	A.I.S.V.-REED VALVE JOINT TUBE	1	
11 1757A-HMC-000	85.70	A.I.A.C. ASSY.	1	
12 17590-HMC-000	209.10	A.I.S.V. ASSY	1	
13 90682-V02-900	3.10	TUBE CLAMPER D11.5	1	
14 95002-80000	1.00	TUBE CLIP C12	2	
15 95003-23032-60	3.10	V TUBE	1	

※ Please check the color & stripe information according to the color index !



※N/A = SUBSTITUTE

※Y = EXCHANGEABLE

※N = NOT

TEAMWORLD Sdn. Bhd. 2009.08

PRICE SHOWN IS PER PIECE. Product image price are approximate guide only.
Prices shown are subject to change without prior notice.

F01 FRONT COVER & HEAD LIGHT

LM25W5-MC(GTS250 EFI CKD TO 馬來西亞)

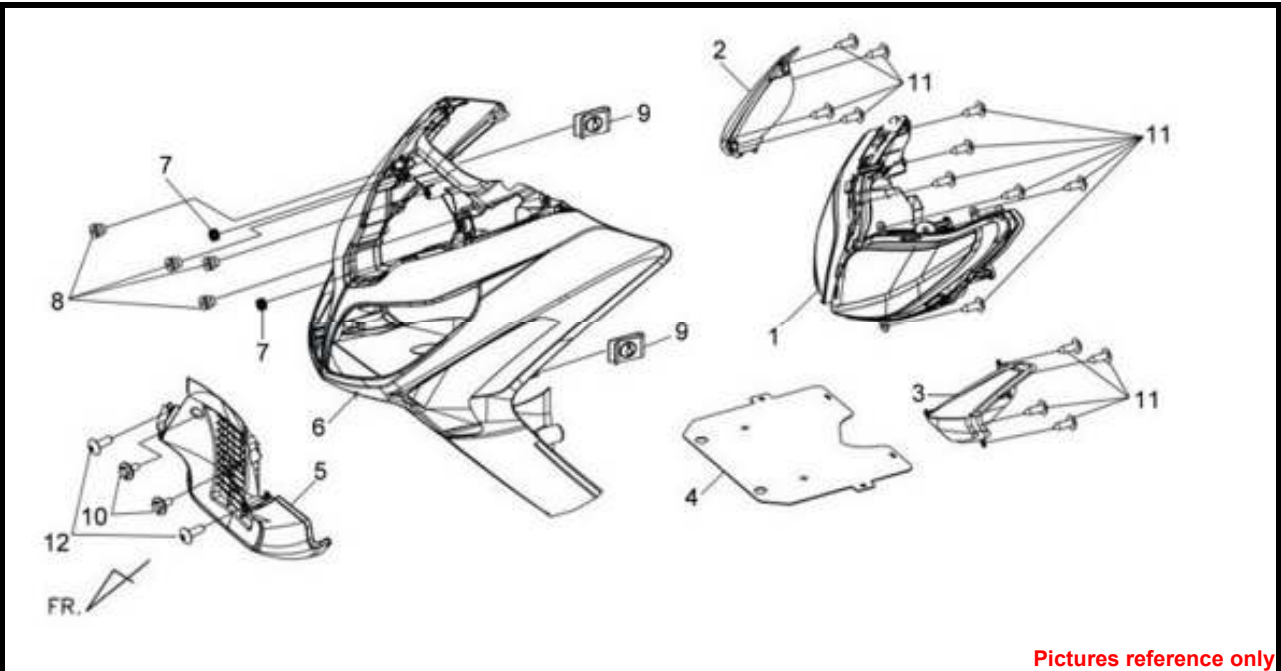

Pictures reference only

PARTS NUMBER	SELLING PRICE (RM/PCS)	DESCRIPTION	QTY	EFFECTIVE DATE	
1 33100-HWA-000	734.60	HEAD LIGHT ASSY	1		
1-1 34901-LVA-000	82.30	HEAD LIGHT BULB (H11/55W)	2		
1-2 33101-HWA-000	359.90	R HEAD LIGHT COMP	1		
1-3 33151-HWA-000	359.90	L HEAD LIGHT COMP	1		
1-4 33102-HWA-000	274.20	R HEAD LIGHT LENS UNIT	1		
1-5 33152-HWA-000	274.20	L HEAD LIGHT LENS UNIT	1		
1-6 33124-HWA-000	20.60	HEAD LIGHT BRKT	1		
1-7 33190-HWA-000	125.20	R HEAD LIGHT LED COUPLER	1		
1-8 33195-HWA-000	125.20	L HEAD LIGHT LED COUPLER	1		
2 33400-HMA-000	342.70	R FR WINKER & FOGGY LAMP	1		
2-1 34905-HMA-000	11.20	BULB WINKER 12V/21W	2		
2-2 34909-HMA-000	75.40	FOGGY BULB 27W	2		
3 33450-HMA-000	359.90	L FR WINKER & FOGGY LAMP	1		
3-1 34905-HMA-000	11.20	BULB WINKER 12V/21W	2		
3-2 34909-HMA-000	75.40	FOGGY BULB 27W	2		
4 61101-HWA-000	18.90	DUST GUARD PLATE	1		
5 64300-HMA-000-JG	123.40	FR UNDER SPOILER BK-433S	1		
5 64300-HMA-000-IP	123.40	FR UNDER SPOILER GY-517S	1		
5 64300-HMA-000-QU	123.40	FR UNDER SPOILER WH-300P	1		
5 64300-HMA-000-SO	126.80	FR UNDER SPOILER S-421S	1		
6 64301-HWA-000-JG	416.70	FR COVER BK-433S	1		
6 64301-HWA-010-JG	416.70	FR COVER BK-433S	1	2009/12/4	Y
6-1 87129-LEA-000	12.10	BODY COVER EMBLEM A	1	2009/12/4	N

PRICE SHOWN IS PER PIECE. Product image price are approximate guide only.
Prices shown are subject to change without prior notice.

6	64301-HWA-000-IP	416.70	FR COVER GY-517S	1		
6	64301-HWA-010-IP	416.70	FR COVER GY-517S	1	2009/12/4	Y
6-1	87129-LEA-000	12.10	BODY COVER EMBLEM A	1	2009/12/4	N
6	64301-HWA-000-QU		FR COVER WH-300P	1		
6	64301-HWA-010-QU	416.70	FR COVER WH-300P	1	2009/12/4	Y
6-1	87129-LEA-000	12.10	BODY COVER EMBLEM A	1	2009/12/4	N
6-2	RM-001-003	15.00	GRAPHIC-SYMPHONY LOGO (SPECIAL EDITION)	2		
6	64301-HWA-000-SO		FR COVER S-421S	1		
6	64301-HWA-010-SO	416.70	FR COVER S-421S	1	2009/12/4	Y
6-1	87129-LEA-000	12.10	BODY COVER EMBLEM A	1	2009/12/4	N
7	64304-X01-000	1.30	FR.COVER RUBBER	2		
8	90118-HLK-000	5.60	GROMMET NUT 5MM	6		
9	90302-M92-000	0.80	SPRING NUT 4MM	2		
10	93404-06016-07	0.80	BOLT WASHER 6X16	2		
11	93903-25320	0.60	TAPPING SCREW 5X16	12		
12	93903-34320	0.60	TAPPING SCREW 4X12	2		

※ Please check the color & stripe information according to the color index !



※ N/A = SUBSTITUTE

※ Y = EXCHANGEABLE

※ N = NOT AVAILABLE

TEAMWORLD INC. 2009.08

PRICE SHOWN IS PER PIECE. Product image price are approximate guide only.
Prices shown are subject to change without prior notice.

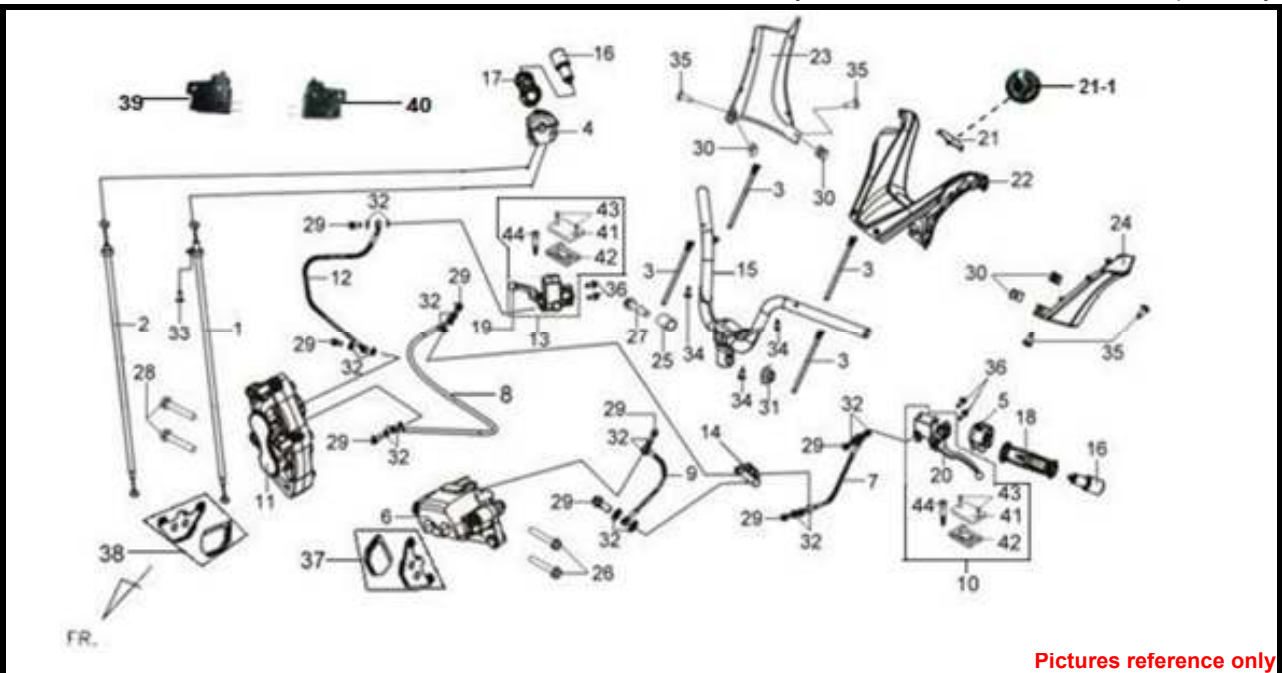

PARTS NUMBER	SELLING PRICE (RM/PCS)	DESCRIPTION	QTY	EFFECTIVE DATE
1 17910-HMA-000	30.80	THROTTLE CABLE A	1	
2 17920-HMA-000	32.50	THROTTLE CABLE B	1	
3 32160-A3A-900	3.30	WIRE BAND 200X8	4	
4 35150-HM1-000	96.00	R HANDLE SW ASSY	1	
5 35200-HNL-000	120.00	L. HANDLE SW. ASSY	1	
6 43100-HMA-000	359.90	RR.CALIPER ASSY S-421S	1	
6-1 222Y-0035	8.60	CALIPER PAD PIN	1	
6-2 222Y-0038	8.60	CALIPER PAD PIN	1	
7 43311-HMA-000	108.00	RR BRAKE HOSE A	1	
8 43312-HMA-000	118.30	RR BRAKE HOSE B	1	
9 43313-HMA-000	188.50	RR BRAKE HOSE C	1	
10 43500-HMA-000	222.90	RR. M/C ASSY	1	
11 45100-HMA-000	497.00	FR. CALIPER ASSY	1	
11-1 2E34-0016	6.10	FR. CALIPER PAD PIN	2	
12 45126-HMA-000	154.20	FR. BRAKE HOSE	1	
13 45500-HMA-000	222.90	FR. M/C ASSY	1	
14 46300-HMA-000	198.80	DELAY VALVE ASSY	1	
15 53100-HMA-000	126.80	STRG HANDLE COMP	1	
16 53104-N02-000	31.50	HANDLE PIPE WT. ASSY.	2	
17 53140-HMA-900	18.90	THROT GRIP COMP	1	
18 53166-H85-000	6.90	L HANDLE GRIP BK-004U	1	
19 53175-HMA-000	22.30	R.HANDLE LEVER	1	
20 53178-HMA-000	22.30	L.HANDLE LEVER	1	

PRICE SHOWN IS PER PIECE. Product image price are approximate guide only.
 Prices shown are subject to change without prior notice.

21	53204-HMA-900	5.80	UP HANDLE COVER CAP(BK-001U)	1	
21-1	87123-HEB-000	22.30	S-LOGO MARK(30MM)	1	
22	53205-HMA-900-KA	22.30	UP HANDLE COVER (BK-001U)	1	
23	53206-HMA-900	15.40	R HANDLE COVER	1	
24	53207-HMA-900	15.40	L. HANDLE COVER	1	
25	53125-M9Q-000	8.60	HANDLE SET COLLAR	1	
26	90104-H9A-000	2.00	FLANGE BOLT 8X45	2	
27	90106-M9Q-000	3.10	FLANGE BOLT 10X50	1	
28	90104-H5K-000	2.50	FLANGE BOLT 8X40	2	
29	90145-M9Q-000	3.30	OIL BOLT 10X22	2	
30	90302-M92-000	0.80	SPRING NUT 4MM	4	
31	90304-M9Q-000	4.80	NUT U FLANGE 10MM	1	
32	90545-M9Q-000	1.00	OIL BOLT WASHER	16	
33	93891-05012-07	0.80	WASHER SCREW 5X12	1	
34	93903-34320	0.60	TAPPING SCREW 4X12	3	
35	93903-34380	0.60	TAPPING SCREW 4X12	4	
36	95801-06022-07	0.80	FLANGE BOLT 6X22	4	
37	43108-HMA-000-A	74.60	RR. BRAKE PAD SET	1	
38	45105-HMA-000-A	133.70	FR. BRAKE PAD SET	1	
39	35340-KBN-900	10.20	FR. STOP SW. ASSY(R)	1	
40	35350-KBN-900	14.80	RR. STOP SWITCH ASSY(L)	1	
41	1V93-0228	6.10	MASTER CYLINDER CAP	2	
42	1652-0029	4.10	M/C LID GASKET	2	
43	1484-0031	0.80	MASTER CYLINDER CAP SCREW	4	
44	1484-0039	2.50	HANDLE LEVER SCREW	2	

※ Please check the color & stripe information according to the color index !



※N/A = SUBSTITUTE

※Y = EXCHANGEABLE

※N = NOT AVAILABLE. 2009.08

PRICE SHOWN IS PER PIECE. Product image price are approximate guide only.
Prices shown are subject to change without prior notice.

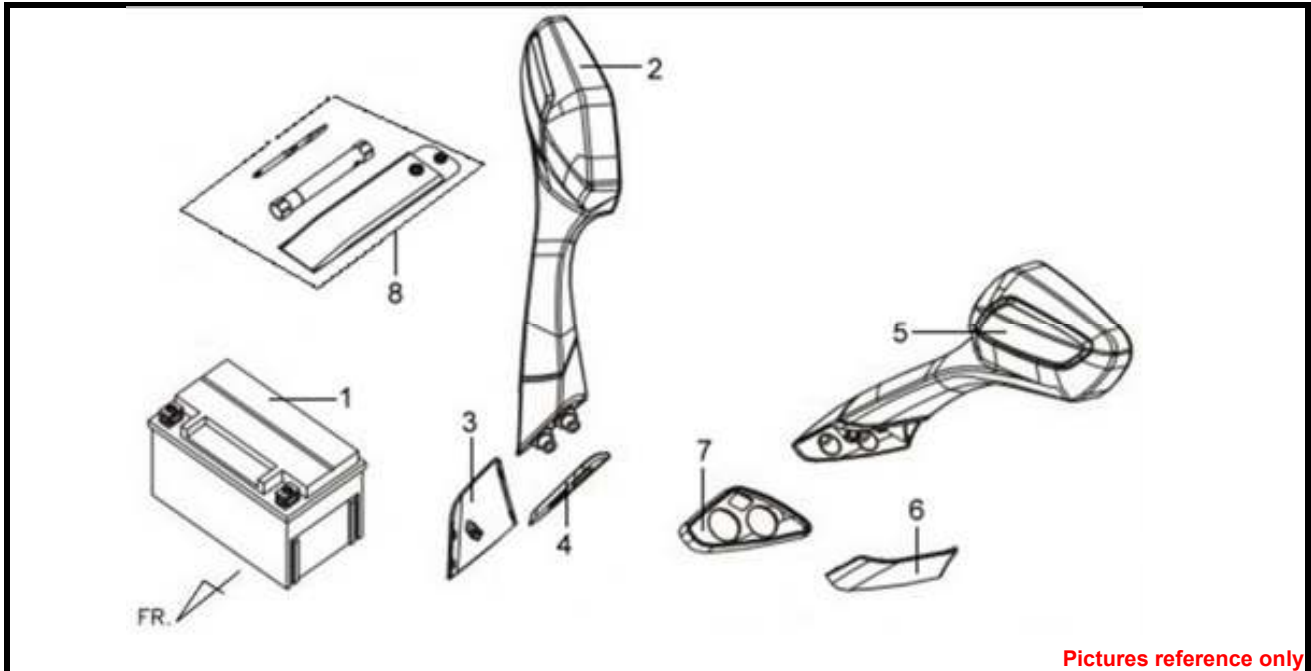

PARTS NUMBER	SELLING PRICE (RM/PCS)	DESCRIPTION	QTY	EFFECTIVE DATE
1 AC-YTX12-BS(HW)	160.00	BATTERY ASSY.(YTX12-BS 12AH)	1	
2 88110-HMA-900-JG	147.50	R BACK MIRROR ASSY.BK-433S	1	
2 88110-HMA-900-IP	147.50	R BACK MIRROR ASSY.GY-517S	1	
2 88110-HMA-900-QU	147.50	R BACK MIRROR ASSY.WH-300P	1	
2 88110-HMA-900-SO	147.50	R BACK MIRROR ASSY.S-421S	1	
3 88111-HMA-000	20.60	R. BASE COVER	1	
4 88112-HMA-000	5.50	BACK MIRROR PAD	1	
5 88120-HMA-900-JG	147.50	L BACK MIRROR ASSY.BK-433S	1	
5 88120-HMA-900-IP	147.50	L BACK MIRROR ASSY.GY-517S	1	
5 88120-HMA-900-QU	147.50	L BACK MIRROR ASSY.WH-300P	1	
5 88120-HMA-900-SO	147.50	L BACK MIRROR ASSY.S-421S	1	
6 88121-HMA-000	20.60	L. BASE COVER	1	
7 88122-HMA-000	5.50	BACK MIRROR PAD	1	
8 89010-M92-000	27.50	TOOL SET	1	

※ Please check the color & stripe information according to the color index !

※N/A = SUBSTITUTE

※Y = EXCHANGEABLE

※N = NOT AVAILABLE



TEAM WORLD BOND. 2009.08

PRICE SHOWN IS PER PIECE. Product image price are approximate guide only.
Prices shown are subject to change without prior notice.

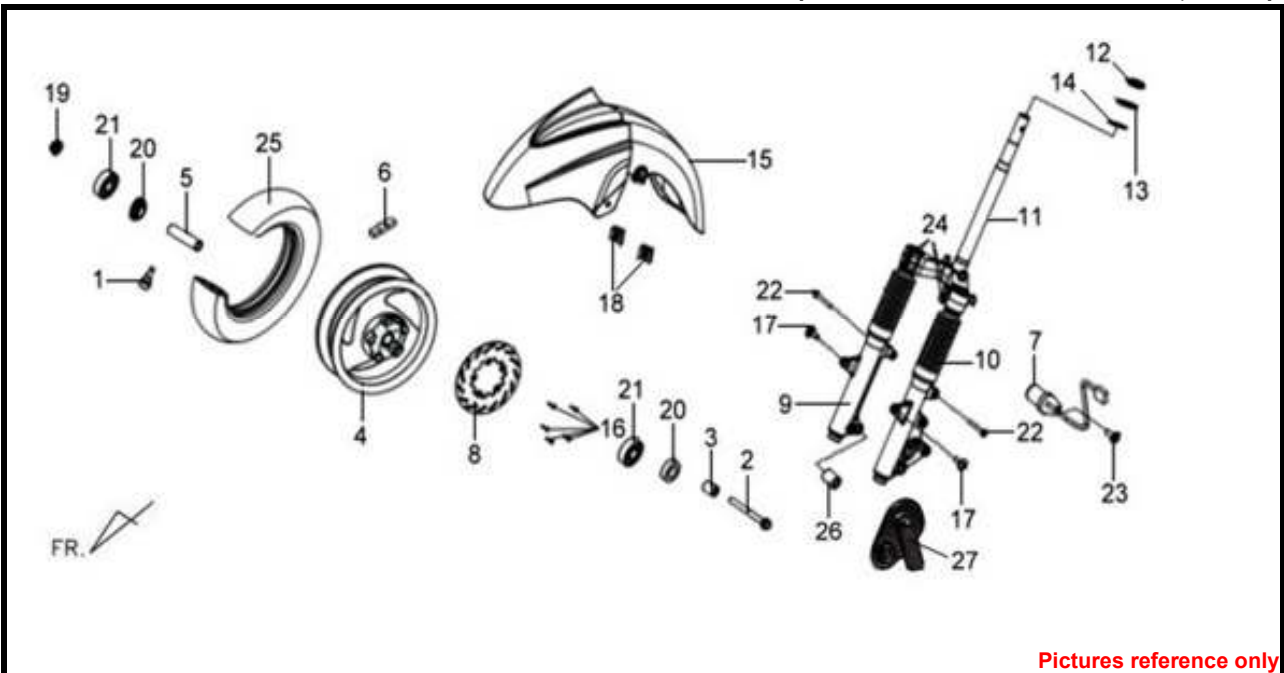

PARTS NUMBER	SELLING PRICE (RM/PCS)	DESCRIPTION	QTY	EFFECTIVE DATE
1 42753-KJ9-000	9.20	VALVE RIM	1	
2 44301-G22-000	13.70	FR. WHEEL AXLE	1	
3 44311-GW0-910	6.10	COLLAR FR. WHEEL SIDE	1	
4 44601-HMA-000	548.40	FR. CAST WHEEL COMP	1	
5 44620-H3A-000	5.80	FR. AXLE DISTANCE COLLAR	1	
6 44720-H9A-000	10.20	BALANCE WEIGHT	1	
7 44800-HMB-000	92.50	SPEED SENSOR ASSY	1	
8 45121-HMB-000-SH	218.30	FR. BRAKE DISK(SILVER)	1	
9 51400-HWA-000	428.50	R.CUSHION ASSY	1	
9-1 91255-HWA-000	29.10	FR.CUSHION OIL SEAL	1	
9-2 91256-HWA-000	29.10	OIL SEAL	1	
9-3 91259-HWA-000	4.50	OIL SEAL STOP RING	1	
9-4 91309-HWA-000	6.90	O-RING	1	
9-5 90103-HWA-000	54.80	FORK BOLT	1	
9-6 51410-HWA-000	205.60	FR.CUSHION PIPE	1	
10 51500-HWA-000	428.50	L.CUSHION ASSY	1	
10-1 91255-HWA-000	29.10	FR.CUSHION OIL SEAL	1	
10-2 91256-HWA-000	29.10	OIL SEAL	1	
10-3 91259-HWA-000	4.50	OIL SEAL STOP RING	1	
10-4 91309-HWA-000	6.90	O-RING	1	
10-5 90103-HWA-000	54.80	FORK BOLT	1	
10-6 51410-HWA-000	205.60	FR.CUSHION PIPE	1	
11 53200-HWA-000	257.10	STEM COMP STRG.	1	

PRICE SHOWN IS PER PIECE. Product image price are approximate guide only.
 Prices shown are subject to change without prior notice.

12	53212-VA3-000	12.10	STRG BOTTOM CONE RACE	1	
13	53214-HMA-000	12.10	STRG. DUST SEAL	1	
14	53215-HHA-000	3.20	S DUST SEAL WASHER(34.5X52X.6)	1	
15	61100-HMA-000-JG	123.40	FR FENDER BK-433S	1	
15	61100-HMA-000-IP	123.40	FR FENDER GY-517S	1	
15	61100-HMA-000-QU	123.40	FR FENDER WH-300P	1	
15	61100-HMA-000-SO	123.40	FR FENDER S-421S	1	
16	90105-KR3-000	4.10	FR. DISK BOLT 8X24	5	
17	90164-M9Q-000	1.30	SCREW SPECIAL 6mm	2	
18	90305-M9Q-000	1.70	CLIP NUT 6MM	2	
19	90306-M9Q-000	6.10	SELF LOCK NUT 12MM	1	
20	90754-M9Q-000-M2	2.50	DUST SEAL 20X32X5	2	
21	90912-M9Q-000-M1	11.00	BEARING 6201LU/2A	2	
22	93891-06050-07	1.00	WASHER SCREW 6X45	2	
23	93893-06016-07	1.00	SCREW WASHER	1	
24	95801-10040-08	2.00	FLANGE BOLT 10X40	4	
25	AC-SB124-110/90-13	127.00	DELI CITY GRIPPER 110/90-13	1	
26	44312-HMA-000	8.60	FR. WHEEL SIDE COLLAR	1	
27	51106-LEA-000	3.30	SPDMT SENSOR COVER	1	

※ Please check the color & stripe information according to the color index !



PRICE SHOWN IS PER PIECE. Product image price are approximate guide only.
Prices shown are subject to change without prior notice.

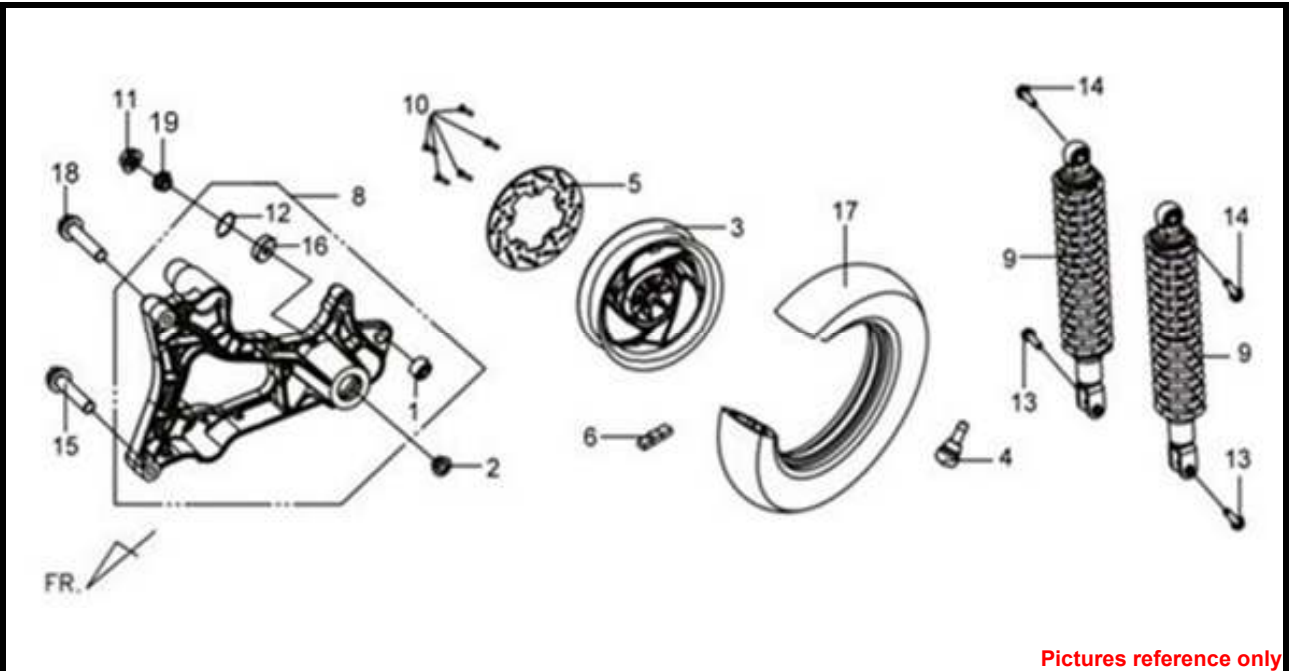

Pictures reference only

PARTS NUMBER	SELLING PRICE (RM/PCS)	DESCRIPTION	QTY	EFFECTIVE DATE
1 11203-GC7-300	3.80	RR.CUSHION RUBBER BUSH	1	
2 42311-H9A-000	15.00	RR. AXLE COLLAR	1	
3 42601-HMA-000	548.40	RR. CAST WHEEL COMP	1	
4 42753-M92-300	8.60	VALVE RIM	1	
5 43121-HMA-000	161.10	RR. BRAKE DISK	1	
6 44720-H9A-000	10.20	BALANCE WEIGHT	1	
8 5210A-HMA-005	315.30	RR. FORK ASSY	1	
9 52400-HMA-000	154.20	RR. CUSHION ASSY	2	
10 90105-KR3-000	4.10	FR. DISK BOLT 8X24	5	
11 90305-M9Q-900	10.20	U NUT 16 MM	1	
12 94524-47000	3.30	CIR CLIP IN47	1	
13 95801-08035-07	1.70	FLANGE BOLT M8X35	2	
14 95801-10040-08	2.00	FLANGE BOLT 10X40	2	
15 95801-10065-07	2.80	FLANGE BOLT	1	
16 96150-63033-10	25.60	RADIAL BALL BEARING 6303U	1	
17 AC-SB124-130/70-13	138.00	DELI CITY GRIPPER 130/70-13	1	
18 95801-10075-07	2.80	FLANGE BOLT	1	
19 42311-H9A-900	18.90	RR. AXLE COLLAR	1	

※ Please check the color & stripe information according to the color index !

※N/A = SUBSTITUTE

※Y = EXCHANGEABLE

※N = NOT AVAILABLE
 **TEAMWORKER** IND. 2009.08

PRICE SHOWN IS PER PIECE. Product image price are approximate guide only.
 Prices shown are subject to change without prior notice.

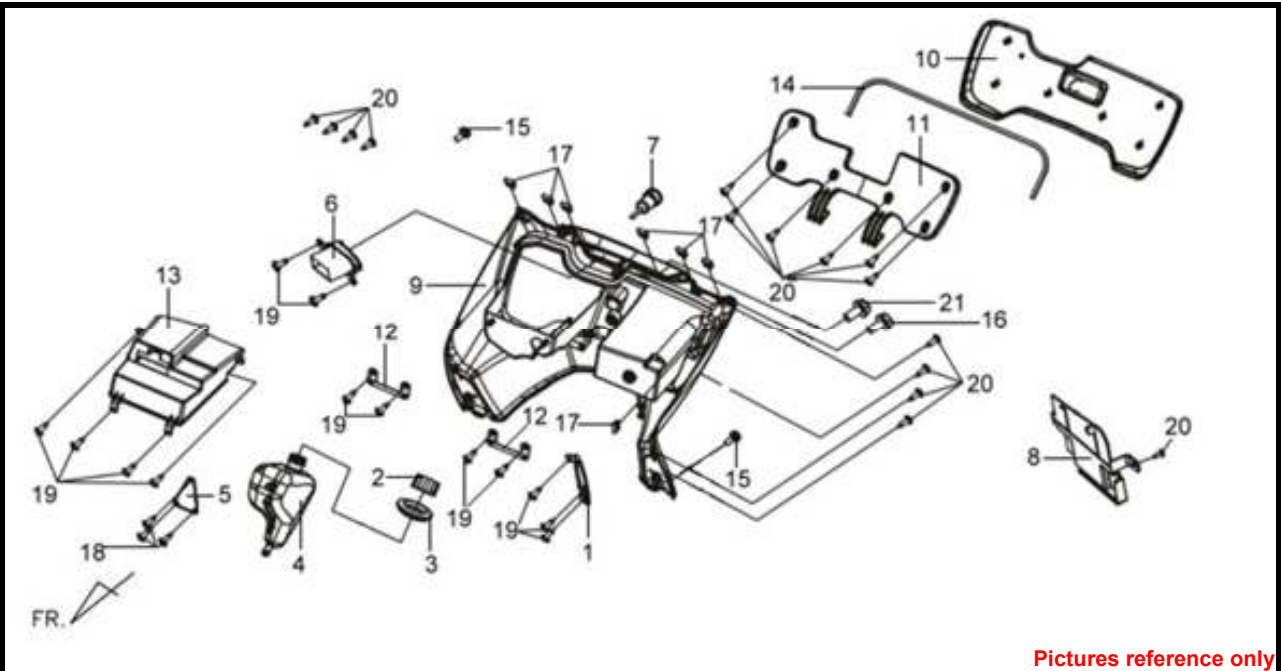

Pictures reference only

PARTS NUMBER	SELLING PRICE (RM/PCS)	DESCRIPTION	QTY	EFFECTIVE DATE
1 17661-HMA-000	15.40	FILLER PIPE STAY	3	
2 19015-HMA-000	44.60	RESERVE TANK CAP	1	
3 19016-HMA-000	1.70	RESERVE TANK TRAY	1	
4 19101-HMA-000	37.70	RESERVE TANK	1	
5 19102-HMA-000	5.20	RESERVE TANK STAY	1	
6 35360-HMA-000	78.80	HAZARD AND FOGGY SW COMP	1	
7 38600-RA1-000	42.50	DC. POWER OUTLET	1	
8 50326-HMA-000	16.50	BATTERY COVER	1	
9 81131-HMA-000-KA	181.00	INNER BOX	1	
10 81141-HMA-000	29.50	INNER BOX LID	1	
11 81142-HMA-000	29.10	INNER BOX LID STIFFENER	1	
12 81143-HMA-000	1.70	INN. BOX LID HINGE STAY	1	
13 81144-HMA-000	20.60	INNER BOX UP CASE	1	
14 81146-HMA-000	5.80	INNER BOX SEAL	1	
15 90111-HKD-000	3.30	BOLT FLANGE 6MM	2	
16 90111-M9Q-900	2.00	FLANGE BOLT(MFZn2-C)6MM	1	
17 90302-M92-000	0.80	SPRING NUT 4MM	6	
18 93903-25320	0.60	TAPPING SCREW 5X16	3	
19 93903-34320	0.60	TAPPING SCREW 4X12	13	
20 93903-34380	0.60	TAPPING SCREW 4X12	15	
21 95801-06012-07	0.80	FLANGE BOLT 6X12	1	

※ Please check the color & stripe information according to the color index !

PRICE SHOWN IS PER PIECE. Product image price are approximate guide only.
Prices shown are subject to change without prior notice.

F07 RADIATOR ASSY.

LM25W5-MC(GTS250 EFI CKD TO 馬來西亞)

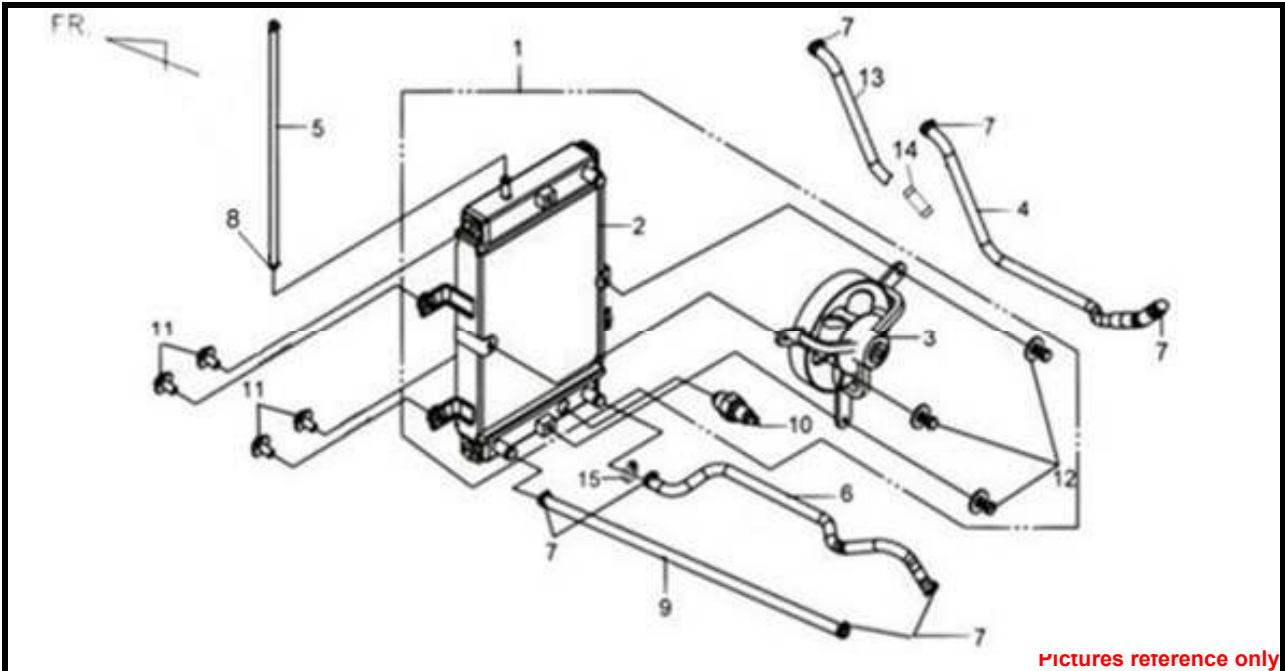

Pictures reference only

PARTS NUMBER	SELLING PRICE (RM/PCS)	DESCRIPTION	QTY	EFFECTIVE DATE	
1 19000-HMA-000	719.90	RADIATOR ASSY	1		
1 19000-HMA-900	612.10	RADIATOR ASSY	1	26/4/2010	N
2 19010-HMA-000	438.80	RADIATOR COMP	1		
2 19010-HMA-900	330.00	RADIATOR COMP	1	2010/4/26	N
3 19005-HMA-000	284.50	SHROUD ASSY	1		
4 19501-HTA-000	34.40	RADIATOR IN. WATER HOSE	1		
4 19501-HTA-900	24.00	RADIATOR IN. WATER HOSE	1	2010/4/26	N
5 19503-HMA-000	15.40	RES. TANK IN. WATER HOSE	1		
6 19505-HMA-000	27.50	ENG. INLET WATER HOSE	1		
6 19505-HMA-900	41.10	ENG. INLET WATER HOSE	1	2010/4/26	N
7 19505-KS6-700	3.30	WATER HOSE CLAMP A	6		
8 19505-M8Q-000		WATER HOSE CLAMP A	2		
8 19505-H5D-900	5.20	HOSE CLAMP	1	2011/10/4	
9 19507-HMA-000	24.00	RES. TANK OUT. WATER HOSE	1		
10 37760-HMA-000	85.70	THERMO. SW	1		
11 93404-06020-08	0.80	WASHER BOLT	4		
12 93405-06012-08	1.30	WASHER BOLT	3		
13 19506-HMA-000		RADIATOR INLET WATER HOSE B	1		
13 19506-HMA-900	20.60	RADIATOR INLET WATER HOSE B	1	2010/4/26	N
14 19509-HTA-900		WATER HOSE 2 WAY JOINT	1		
14 19509-HWA-000	6.90	WATER HOSE 2 WAY JOINT	1	2010/4/26	N
15 19505-REA-000	8.60	HOSE CLAMP	1		

※ Please check the color & stripe information according to the color index !

PRICE SHOWN IS PER PIECE. Product image price are approximate guide only.
Prices shown are subject to change without prior notice.

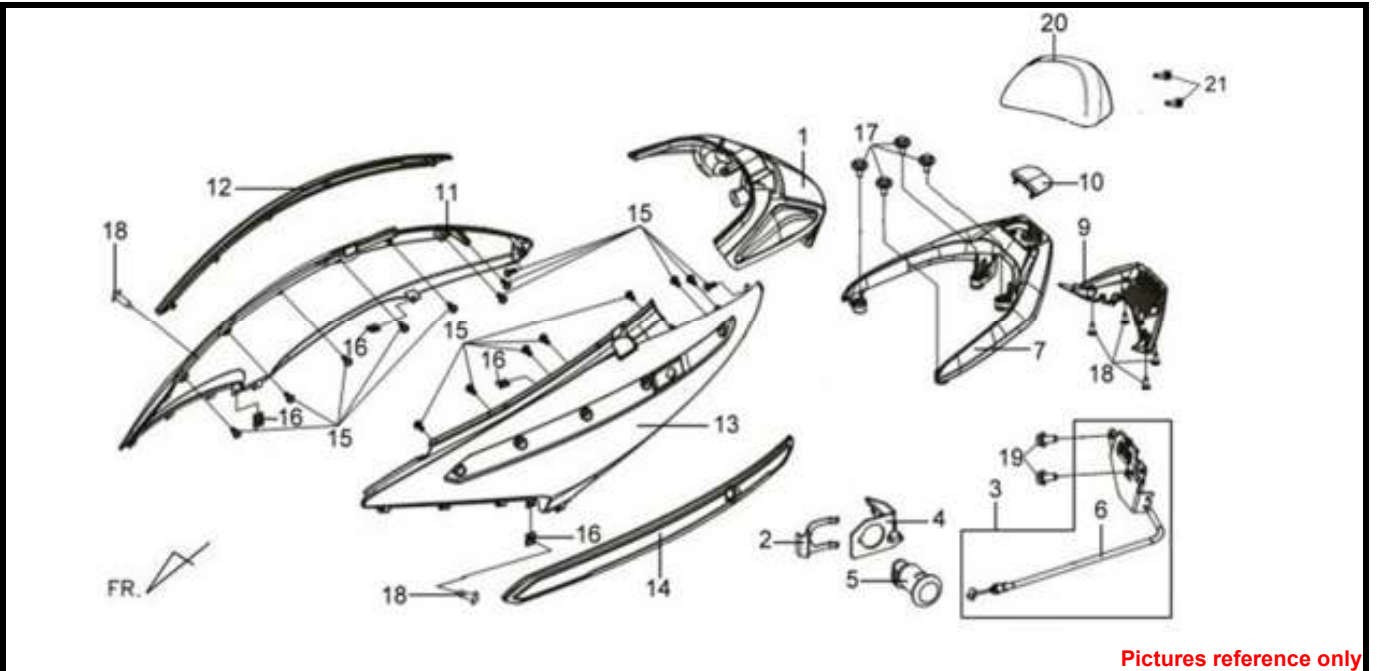

Pictures reference only

PARTS NUMBER	SELLING PRICE (RM/PCS)	DESCRIPTION	QTY	EFFECTIVE DATE
1 33700-HMA-000	462.70	RR. COMB LIGHT ASSY	1	
1-1 33701-HMA-000	22.30	RR COMB.LIGHT LENS	1	
1-2 33711-HMA-000	18.90	RR. R. WINKER LENS	1	
1-3 33721-HMA-000	18.90	RR. L. WINKER LENS	1	
1-4 34905-HMA-000	11.20	BULB WINKER 12V/21W	2	
1-5 34906-HMA-000	12.10	TAIL LIGHT BULB	1	
2 75581-A16-000	2.00	LOCK KEY SET SPRING	1	
3 77230-HMB-000	37.70	SEAT CATCH ASSY	1	
4 77236-HAA-000	1.70	SEAT LOCK WASHER	1	
5 77239-HMA-000	27.50	SEAT LOCK KEY COMP	1	
6 77240-HMA-000	8.60	SEAT LOCK CABLE	1	
7 81200-HWA-000-JG	255.30	RR CARRIER COMP BK-433S	1	
7 81200-HWA-000-IP	255.30	RR CARRIER COMP GY-517S	1	
7 81200-HWA-000-QU	255.30	RR CARRIER COMP WH-300P	1	
7 81200-HWA-000-SO	229.60	RR CARRIER COMP S-421S	1	
9 81210-HMA-000	17.80	RR. CARRIER COVER BK-001U	1	
10 81211-HWA-000-JG	20.60	RR CARRIER CAP BK-433S	1	
10 81211-HWA-000-IP	20.60	RR CARRIER CAP GY-517S	1	
10 81211-HWA-000-QU	20.60	RR CARRIER CAP WH-300P	1	
10 81211-HWA-000-SO	20.60	RR CARRIER CAP S-421S	1	
11 8350G-HM1-000-JG	246.10	R BODY CVOER ASSY.BK-433S	1	
11-1 87126-HM1-000	65.20	RH. BODY COVER EMBLEM	1	
11-2 87129-HML-000	20.60	i MARK	1	

PRICE SHOWN IS PER PIECE. Product image price are approximate guide only.
 Prices shown are subject to change without prior notice.

11-3	RM-001-002	2.00	GRAPHIC-SYMPHONY LOGO	1
11	8350G-HM1-000-IP	246.10	R BODY CVOER ASSY.GY-517S	1
11-1	87126-HM1-000	65.20	RH. BODY COVER EMBLEM	1
11-2	87129-HML-000	20.60	i MARK	1
11-3	RM-001-002	2.00	GRAPHIC-SYMPHONY LOGO	1
11	8350G-HM1-000-QU	246.10	R BODY CVOER ASSY.WH-300P	1
11-1	87126-HM1-000	65.20	RH. BODY COVER EMBLEM	1
11-2	87129-HML-000	20.60	i MARK	1
11-3	RM-001-002	2.00	GRAPHIC-SYMPHONY LOGO	1
11	8350G-HM1-000-SO	246.10	R BODY CVOER ASSY.S-421S	1
11-1	87126-HM1-000	65.20	RH. BODY COVER EMBLEM	1
11-2	87129-HML-000	20.60	i MARK	1
11-3	RM-001-002	2.00	GRAPHIC-SYMPHONY LOGO	1
12	83501-HMA-000-OL	165.30	R BODY COVER GARNISH S-877U/BK-001U	1
13	8360G-HM1-000-JG	246.10	L BODY COVER ASSY.BK-433S	1
13-1	87126-HM1-000	65.20	RH. BODY COVER EMBLEM	1
13-2	87129-HML-000	20.60	i MARK	1
13-3	RM-001-002	2.00	GRAPHIC-SYMPHONY LOGO	1
13	8360G-HM1-000-IP	246.10	L BODY COVER ASSY.GY-517S	1
13-1	87126-HM1-000	65.20	RH. BODY COVER EMBLEM	1
13-2	87129-HML-000	20.60	i MARK	1
13-3	RM-001-002	2.00	GRAPHIC-SYMPHONY LOGO	1
13	8360G-HM1-000-QU	246.10	L BODY COVER ASSY.WH-300P	1
13-1	87126-HM1-000	65.20	RH. BODY COVER EMBLEM	1
13-2	87129-HML-000	20.60	i MARK	1
13-3	RM-001-002	2.00	GRAPHIC-SYMPHONY LOGO	1
13	8360G-HM1-000-SO	246.10	L BODY COVER ASSY.S-421S	1
13-1	87126-HM1-000	65.20	RH. BODY COVER EMBLEM	1
13-2	87129-HML-000	20.60	i MARK	1
13-3	RM-001-002	2.00	GRAPHIC-SYMPHONY LOGO	1
14	83601-HMA-000-OL	165.30	L BODY COVER GARNISH S-877U/BK-001U	1
15	90106-H2G-000	0.40	FLANGE BOLT 4X12	10
16	90302-M92-000	0.80	SPRING NUT 4MM	4
17	93406-08012-00	1.30	WASHER BOLT 8X12	4
18	93903-34380	0.60	TAPPING SCREW 4X12	6
19	95801-06012-08	0.80	FLANGE BOLT	2
20	77400-HWA-000-JG	188.50	RR BACK SEAT ASSY BK-433S	1
20	77400-HWA-000-IP	188.50	RR BACK SEAT ASSY GY-517S	1
20	77400-HWA-000-QU	188.50	RR BACK SEAT ASSY WH-300P	1
20	77400-HWA-000-SO	188.50	RR BACK SEAT ASSY S-421S	1
21	93406-08020-07	1.30	WASHER BOLT 8*20	2

※ Please check the color & stripe information according to the color index !



PRICE SHOWN IS PER PIECE. Product image price are approximate guide only.
Prices shown are subject to change without prior notice.

F09 SEAT & LUGGAGE BOX

LM25W5-MC(GTS250 EFI CKD TO 馬來西亞)

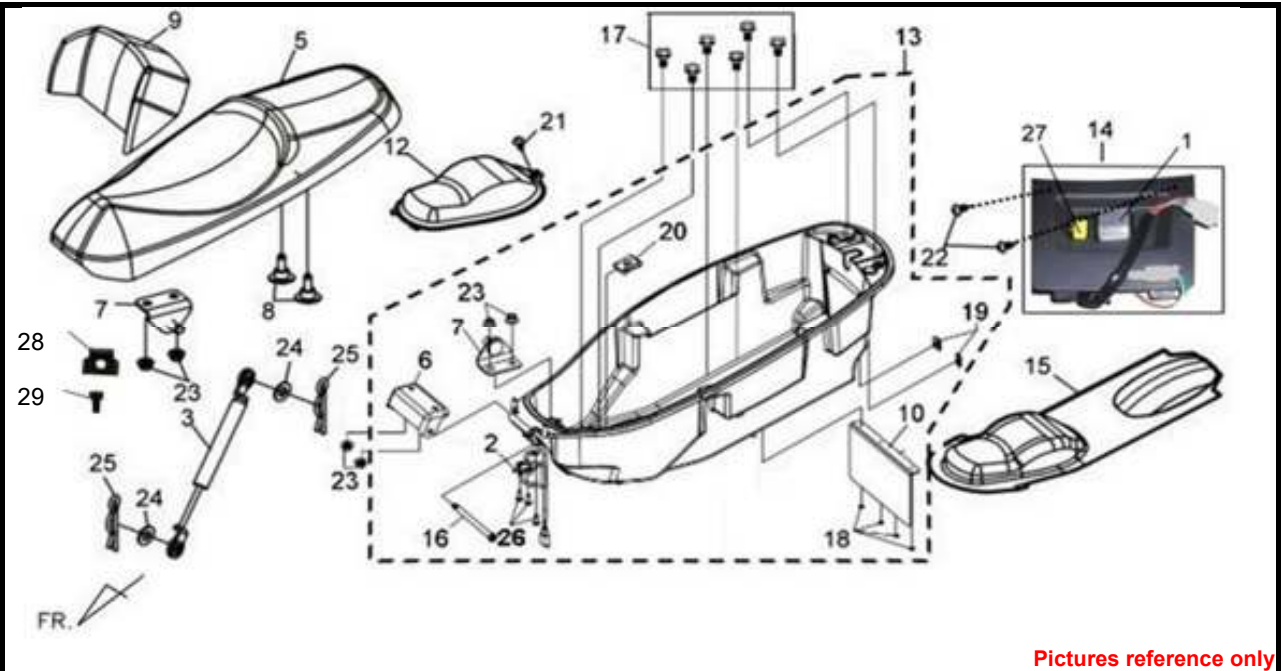

Pictures reference only

PARTS NUMBER	SELLING PRICE (RM/PCS)	DESCRIPTION	QTY	EFFECTIVE DATE	
1 35370-M9P-000	36.00	LUGGAGE BOX LIGHT ASSY	1		
2 35380-HMA-000	32.50	SEAT OPEN LAMP SW	1		
3 74480-HMA-010	109.20	OPEN STAY	1		
5 77200-HWA-000		DOUBLE SEAT COMP BK-001L	1		
5 77200-HWA-010-T1	640.30	DOUBLE SEAT COMP BK-001L	1	2009/12/4	Y
6 77201-HMA-900	17.10	SEAT HINGE	1		
7 74481-HMA-000	20.60	SEAT OPEN STAY BRKT.	1		
8 77203-HMA-010	5.80	BACK SEAT SET BOLT	2		
9 77300-HWA-000	130.20	BACK SEAT ASSY	1		
9 77300-HWA-010-T1	130.20	BACK SEAT ASSY BK-001L	1	2009/12/4	Y
10 80104-HMA-000	4.10	SPLASH GUARD PLATE	1		
12 81257-HMA-000	20.60	MAINT COVER	1		
13 8125A-HMA-008	253.70	LUGGAGE BOX ASSY(BK-001U)	1		
13-1 87505-HMA-000	0.80	TIRE CAUTION MARK	1		
14 8125B-HML-000	72.00	LUG BOX RR COVER ASSY.	1		
15 83630-HMA-000	47.90	LUGGAGE BOX MAT	1		
16 90106-HMA-000	5.20	HINGE PIN	1		
17 90111-M9Q-800	2.00	FLANGE BOLT 6MM	6		
18 90301-GE0-000	1.00	CLIP NUT	4		
19 90302-M92-000	0.80	SPRING NUT 4MM	2		
20 90677-GR1-003	2.00	CLIP NUT 5MMX0.8	1		
21 93891-05016-07	1.30	WASH SCREW 5X16	1		
22 93903-34380	0.60	TAPPING SCREW 4X12	2		

PRICE SHOWN IS PER PIECE. Product image price are approximate guide only.
 Prices shown are subject to change without prior notice.

23	94050-06080	1.00	FLANGE NUT 6MM	6		
24	94101-08800	0.80	PLAIN WASHER 8MM	2		
25	94251-08400	0.80	LOCK PIN 8MM (LATCH PIN)	2		
26	93903-34380	0.60	TAPPING SCREW 4X12	3		
27	36600-A1A-000	17.10	ENG.START CONTROL SWITCH	1		
27	36600-A1A-010	17.10	ENG.START CONTROL SW	1	2009/11/2	N
27	36600-A1A-200	18.90	ENG. START CONTROL SW	1	2013/8/1	Y
28	77204-HMA-000	2.00	LAMP SW.STAY	1	1/1/2007	
29	93406-05010-07	1.30	WASHER BOLT 5*10	1		

※ Please check the color & stripe information according to the color index !



※N/A = SUBSTITUTE

※Y = EXCHANGEABLE

※N = NOT AVAILABLE. 2009.08

TEAMWORLD

PRICE SHOWN IS PER PIECE. Product image price are approximate guide only.
Prices shown are subject to change without prior notice.

F10 FLOOR PANEL & SIDE COVER

LM25W5-MC(GTS250 EFI CKD TO 馬來西亞)

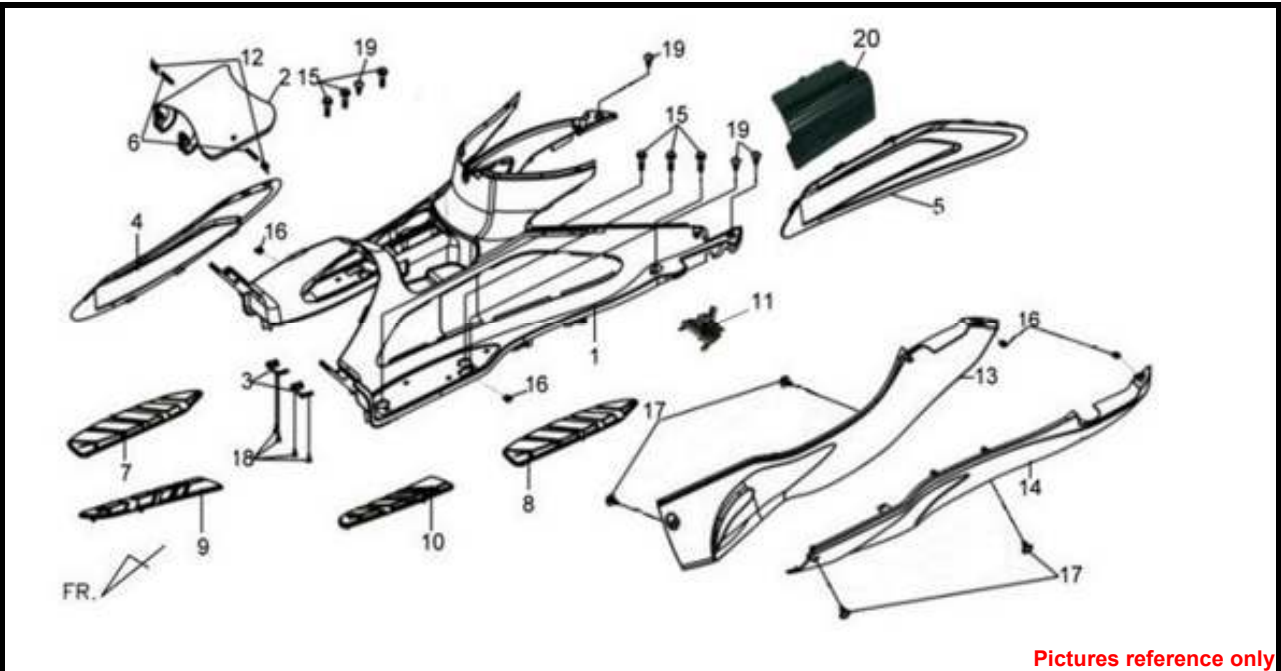

Pictures reference only

PARTS NUMBER	SELLING PRICE (RM/PCS)	DESCRIPTION	QTY	EFFECTIVE DATE
1 64310-HMA-020-KA	134.90	FLOOR PANEL BK-001U	1	
2 64311-HMA-020-KA	14.40	FLOOR BOX LID	1	
3 64312-HMA-000	2.00	FLOOR BOX LID HINGE STAY	1	
4 64313-HMA-000	14.40	R. FLOOR GARNISH	1	
5 64314-HMA-000	14.40	L. FLOOR GARNISH	1	
6 64315-HMA-000	2.50	LID HINGE PIN	2	
7 64321-HMA-000	17.10	R FLOOR MAT A	1	
8 64322-HMA-000	17.10	L FLOOR MAT A	1	
9 64323-HMA-000	17.10	R FLOOR MAT B	1	
10 64324-HMA-000	17.10	L FLOOR MAT B	1	
11 6432C-HMA-000	17.10	FLOOR BOX LID SPG ASSY	1	
12 81153-HMA-010	1.00	COIN BOX LID SPRING	1	
13 8352G-HWA-000-JG	102.90	R.SIDE COVER SET BK-433S	1	
13-1 87123-HWA-000-S	2.80	SYM STRIPE S-480S	1	
13 8352G-HWA-000-IP	102.90	R.SIDE COVER SET GY-517S	1	
13-1 87123-HWA-000-S	2.80	SYM STRIPE S-480S	1	
13 8352G-HWA-000-QU	102.90	R.SIDE COVER SET WH-300P	1	
13-1 87123-HWA-000-S	2.80	SYM STRIPE S-480S	1	
13 8352G-HWA-000-SO	102.90	R.SIDE COVER SET S-421S	1	
13-1 87123-HWA-000-S	2.80	SYM STRIPE S-480S	1	
14 8362G-HWA-000-JG	102.90	L.SIDE COVER SET BK-433S	1	
14-1 87123-HWA-000-S	2.80	SYM STRIPE S-480S	1	
14 8362G-HWA-000-IP	102.90	L.SIDE COVER SET GY-517S	1	

PRICE SHOWN IS PER PIECE. Product image price are approximate guide only.
Prices shown are subject to change without prior notice.

14-1	87123-HWA-000-S	2.80	SYM STRIPE S-480S	1	
14	8362G-HWA-000-QU	102.90	L.SIDE COVER SET WH-300P	1	
14-1	87123-HWA-000-S	2.80	SYM STRIPE S-480S	1	
14	8362G-HWA-000-SO	102.90	L.SIDE COVER SET S-421S	1	
14-1	87123-HWA-000-S	2.80	SYM STRIPE S-480S	1	
15	93903-44380	1.00	TAPPING SCREW 4X12	6	
16	90302-M92-000	0.80	SPRING NUT 4MM	4	
17	93891-05016-07	1.30	WASH SCREW 5X16	4	
18	93903-34320	0.60	TAPPING SCREW 4X12	4	
19	93903-34380	0.60	TAPPING SCREW 4X12	4	
20	64319-HMA-000-KA	6.10	FRAME NUMBER LID (BK-001U)	1	

※ Please check the color & stripe information according to the color index !



※N/A = SUBSTITUTE

※Y = EXCHANGEABLE

※N = NOT AVAILABLE. 2009.08

PRICE SHOWN IS PER PIECE. Product image price are approximate guide only.
Prices shown are subject to change without prior notice.

F11 WIND SCREEN & METER VISOR LM25W5-MC(GTS250 EFI CKD TO 馬來西亞)

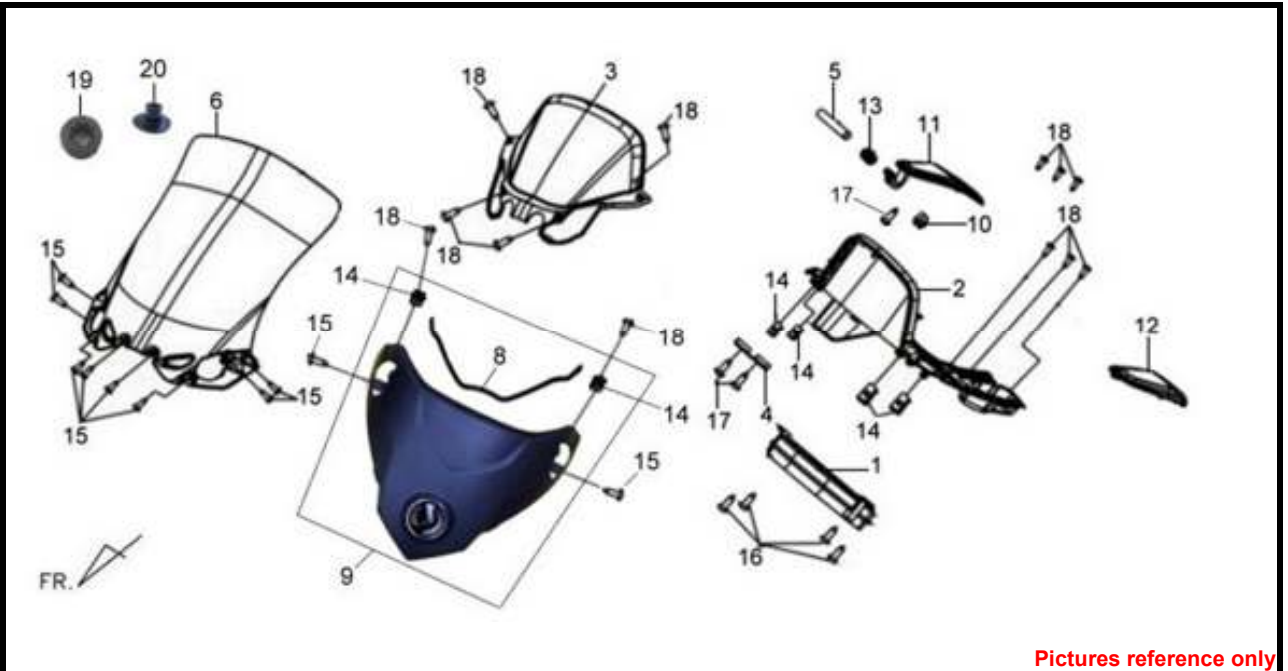

Pictures reference only

PARTS NUMBER	SELLING PRICE (RM/PCS)	DESCRIPTION	QTY	EFFECTIVE DATE	
1 37200-HT2-000	788.40	METER ASSY	1		
1-1 34902-HMA-000	6.70	BULB(T4)	4		
1-2 34907-HMA-000	7.50	BULB(T4.7)1.4W	2		
1-3 37211-HMA-000	34.40	METER LENS	1		
2 53208-HMA-020	44.60	METER PANEL	1		
2 53208-HMA-030	44.60	METER PANEL	1	2010/1/26	N
3 53209-HMA-000	18.90	METER VISOR	1		
4 64312-HMA-000	2.00	FLOOR BOX LID HINGE STAY	1		
5 64315-HMA-000	2.50	LID HINGE PIN	1		
6 6710A-HWA-000	305.00	WIND SCREEN SET	1		
6-1 87121-H85-000	17.10	SYM MARK(POLY)	1		
6-2 87125-HMA-000	49.80	WIND SCREEN STRIPE	1		
8 67111-HWA-000	6.10	WIND SCREEN GARNISH RUB.SEAL	1		
9 6711A-HWA-000	122.70	WIND SCREEN GARNISH ASSY.GY-7450U	1		
9-1 87123-TFS-000	15.40	S-LOGO 50MM(POLY)	1		
9-1 87123-HWF-000		S-LOGO 50MM(PU-AL)	1	2011/8/30	
10 81134-HMA-000	13.30	INNER BOX HOOK	1		
10 8115B-HMA-000	9.30	COIN BOX LOCK ASSY	1	2010/4/1	N
11 81151-HMA-020	14.10	COIN BOX LID BK-001U	1		
11 81151-HMA-030	14.10	COIN BOX LID BK-001U	1	2010/1/26	N
11 8115A-HMA-010	19.90	COIN BOX LID ASSY BK-001U	1	2010/4/1	N
12 81152-HMA-000	17.10	RES TANK LID	1		
13 81153-HMA-010	1.00	COIN BOX LID SPRING	1		

PRICE SHOWN IS PER PIECE. Product image price are approximate guide only.
Prices shown are subject to change without prior notice.

14	90302-M92-000	0.80	SPRING NUT 4MM	6		
15	90119-HMA-000	1.00	SCREW WASHER 5X18	6		
16	93903-25320	0.60	TAPPING SCREW 5X16	4		
17	93903-34320	0.60	TAPPING SCREW 4X12	3		
18	93903-34380	0.60	TAPPING SCREW 4X12	12		
19	64304-X01-000	1.30	FR.COVER RUBBER	2		
20	67101-HMA-000	4.50	WINDSCREEN SCREW CAP	2		

※ Please check the color & stripe information according to the color index !



※N/A = SUBSTITUTE

※Y = EXCHANGEABLE

※N = NOT AVAILABLE. 2009.08

PRICE SHOWN IS PER PIECE. Product image price are approximate guide only.
Prices shown are subject to change without prior notice.

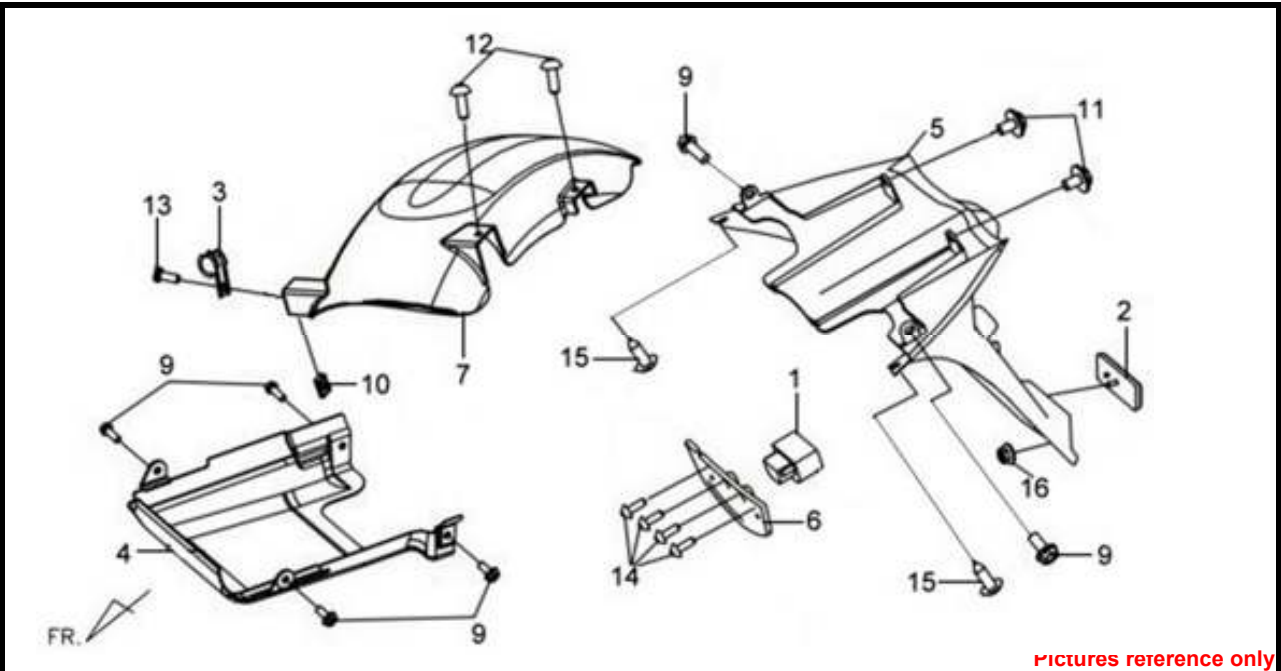

PARTS NUMBER	SELLING PRICE (RM/PCS)	DESCRIPTION	QTY	EFFECTIVE DATE
1 33740-HMA-000	24.00	LICENSE LIGHT ASSY	1	
2 33741-M9A-000	10.20	RR. REFLECTOR	1	
3 45156-H3C-000	3.60	RR. BRAKE HOSE CLAMP	1	
4 50611-HMA-000	25.60	UNDER COVER BK-001U	1	
5 80100-HMA-000	44.60	RR.FENDER	1	
6 80102-HMA-000	5.80	LICENSE LIGHT BRKT.	1	
7 80106-HMA-000	18.30	RR. MUDGUARD (BK-001U)	1	
9 90111-M9Q-900	2.00	FLANGE BOLT(MFZn2-C)6MM	6	
10 90677-GR1-003	2.00	CLIP NUT 5MMX0.8	1	
11 93404-06016-08	0.80	BOLT WASHER 6X16	2	
12 93891-05016-07	1.30	WASH SCREW 5X16	2	
13 93891-05040-07	0.80	WASHER XCREW	1	
14 93903-34320	0.60	TAPPING SCREW 4X12	4	
15 93903-34380	0.60	TAPPING SCREW 4X12	2	
16 94050-05080	0.80	FLANGE NUT 5MM	1	

※ Please check the color & stripe information according to the color index !

※N/A = SUBSTITUTE

※Y = EXCHANGEABLE

※N = NOT



TEAM WORLD BOND. 2009.08

PRICE SHOWN IS PER PIECE. Product image price are approximate guide only.
Prices shown are subject to change without prior notice.

F13 FUEL TANK ASSY

LM25W5-MC(GTS250 EFI CKD TO 馬來西亞)

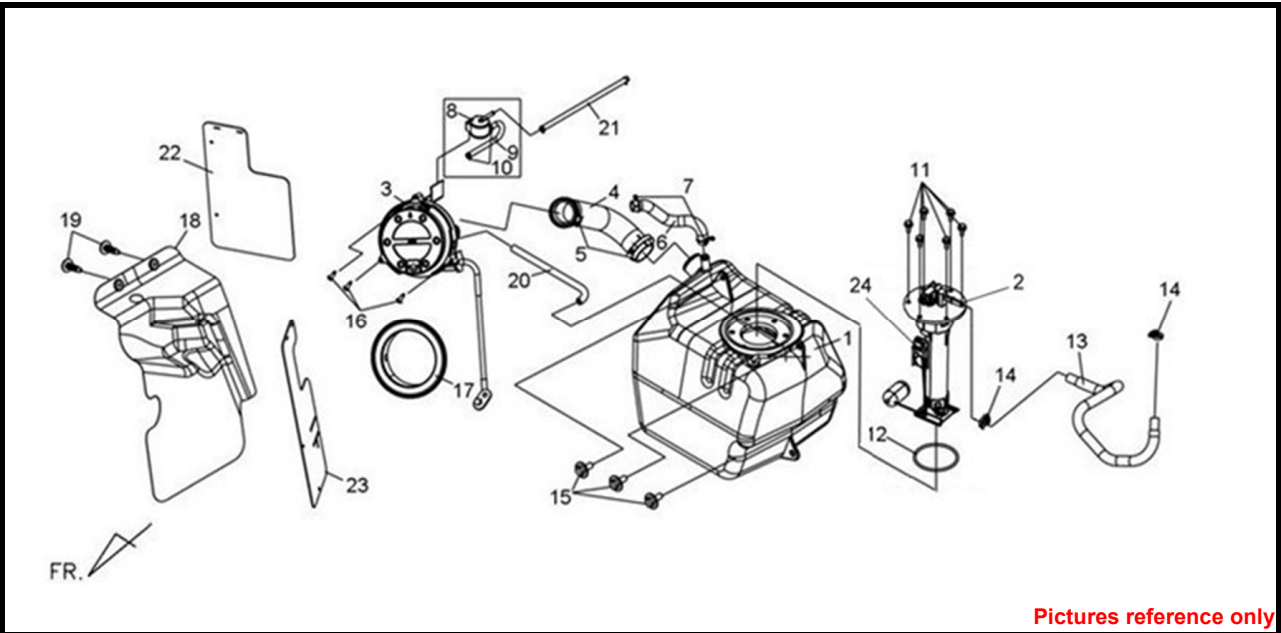

Pictures reference only

PARTS NUMBER	SELLING PRICE (RM/PCS)	DESCRIPTION	QTY	EFFECTIVE DATE
1 17500-HMC-000	143.90	FUEL TANK	1	
2 1670A-LEA-000	660.60	FUEL PUMP ASSY.	1	
2-1 16711-M9Q-000	65.20	FUEL PUMP FILTER SCREEN	1	
2-2 16712-M9Q-000	4.10	PUSH NUT	1	
3 1766A-HMA-000	143.90	FILLER PIPE ASSY	1	
4 17651-HMA-000	17.10	FUEL TANK TUBE	1	
5 17652-TAA-000	5.20	FILLER TUBE CLIP	2	
6 17653-HMA-000	8.20	BREATHER TUBE	1	
7 17369-KB4-670	2.50	TUBE CLIP	2	
8 17581-HMA-000	27.50	FUEL CUT VALVE(LIYANG)	1	
9 95005-45100-20	1.30	TUBE	1	
10 95002-02080	0.80	BREATHER TUBE CLIP B8	2	
11 90105-HMC-000	1.30	FUEL PUMP BOLT	6	
12 37801-A5L-000	9.30	FUEL FILTER PACKING	1	
13 16730-HMC-000	18.90	FUEL TUBE	1	
14 19505-H5D-900	5.20	HOSE CLAMP	2	
15 93404-06016-08	0.80	BOLT WASHER 6X16	3	
16 93903-34380	0.60	TAPPING SCREW 4X12	3	
17 17509-HMA-000	5.80	FILLER PIPE COVER	1	
18 17508-HMA-000	24.00	FUEL TANK HEAT GUARD	1	
19 93893-06016-07	1.00	SCREW WASHER	2	
20 17654-HMA-000	6.90	BREATHER TUBE	1	
21 17585-HMA-000	10.20	TANK-FCV TUBE	1	
22 19017-HMA-000	8.60	RH. HEAT GUARD PLATE	1	
23 19018-HMA-000	8.60	LH. HEAT GUARD PLATE	1	
24 37800-HWA-000	41.10	FUEL UNIT COMP	1	

PRICE SHOWN IS PER PIECE. Product image price are approximate guide only.
 Prices shown are subject to change without prior notice.

24	37800-HWA-010	41.10	FUEL UNIT COMP	1	2013/6/17	Y
----	----------------------	-------	----------------	---	-----------	---

PRICE SHOWN IS PER PIECE. Product image price are approximate guide only.
Prices shown are subject to change without prior notice.

F14 WIRE HARNESS & ELECTRIC PART LM25W5-MC(GTS250 EFI CKD TO 馬來西亞)

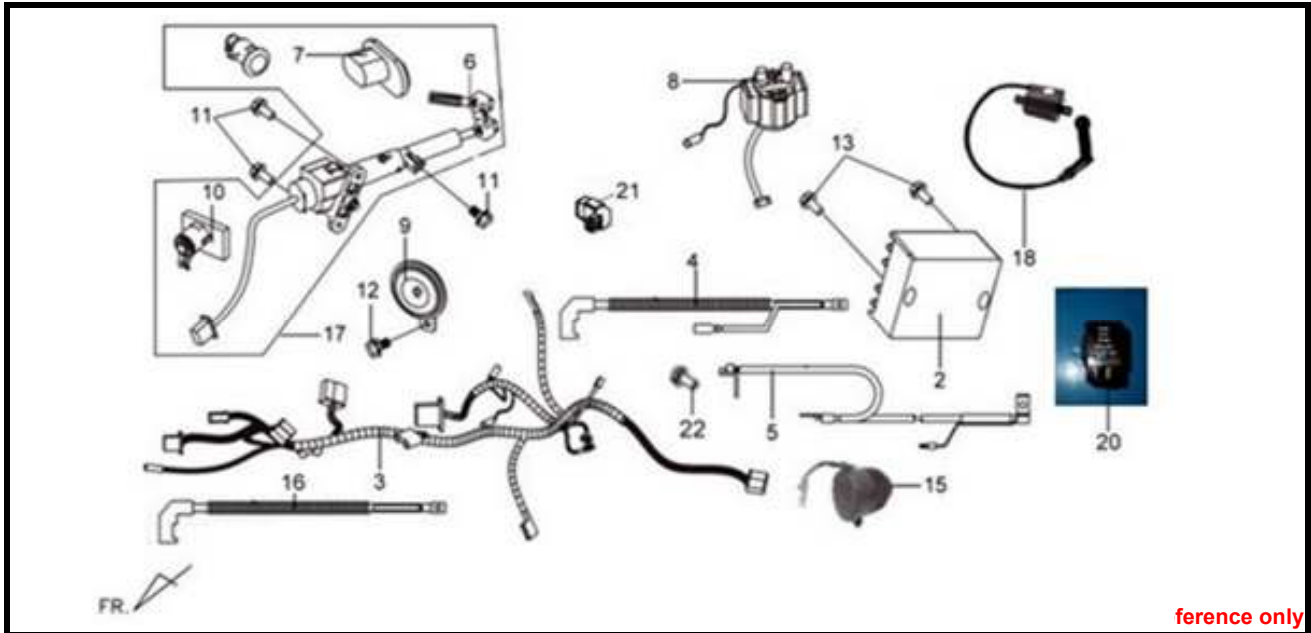

reference only

PARTS NUMBER	SELLING PRICE (RM/PCS)	DESCRIPTION	QTY	EFFECTIVE DATE	
2 31600-HMA-000	264.30	REG. REC. COMP	1		
2 31600-HMA-010	281.00	REG. REC ASSY.	1	2009/12/21	N
2 31600-HMA-020	281.00	REG. REC. COMP	1	2011/12/8	N
3 32100-HML-010	925.50	WIRE HARNESS	1		
3 32100-HML-020	925.50	WIRE HARNESS	1	2009/11/2	N
3 32100-HML-110	925.50	WIRE HARNESS	1	2012/1/19	
4 32411-HMA-000	34.40	CABLE BATTERY	1		
5 32412-HMA-000	24.00	CABLE EARTH	1		
6 35111-HMA-100-A01/20	40.70	KEY	1		
6 35111-HMA-100-B01/20	40.70	KEY	1		
7 35110-HMA-000	41.10	SHUTTER COMP	1		
8 35860-HMC-000	56.60	START MAG. SET	1		
8 35860-HMC-010	56.60	START MAG. SET	1	2010/10/18	Y
9 38110-HMA-000	39.40	HORN COMP	1		
10 77233-HMA-000	37.70	INNER BOX LOCK ASSY	1		
11 90085-HHA-900	2.00	SELF LOCKING BOLT 6*16	3		
12 95801-08016-08	0.80	FLANGE BOLT 8X16	1		
13 95801-06016-08	1.00	FLANGE BOLT 6X16	2		
15 38600-RA1-000	42.50	DC. POWER OUTLET	1		
16 32415-HMA-010	25.60	EARTH CABLE B	1		
17 35010-HMA-100	339.40	KET SET	1		
18 3051A-HMA-010	116.50	IGNITION COIL ASSY	1		
20 38800-H5B-000	36.00	ELECTRIC RELAY UNIT	1		
21 3043A-REA-000	49.80	BATTERY OPEN CONTROL ASSY	1		
22 90110-FYA-000	1.70	FLANGE BOLT 6X14	1	2012/5/28	

PRICE SHOWN IS PER PIECE. Product image price are approximate guide only.
Prices shown are subject to change without prior notice.

F15 MAIN STAND & FR. COVER STAY LM25W5-MC(GTS250 EFI CKD TO 馬來西亞)

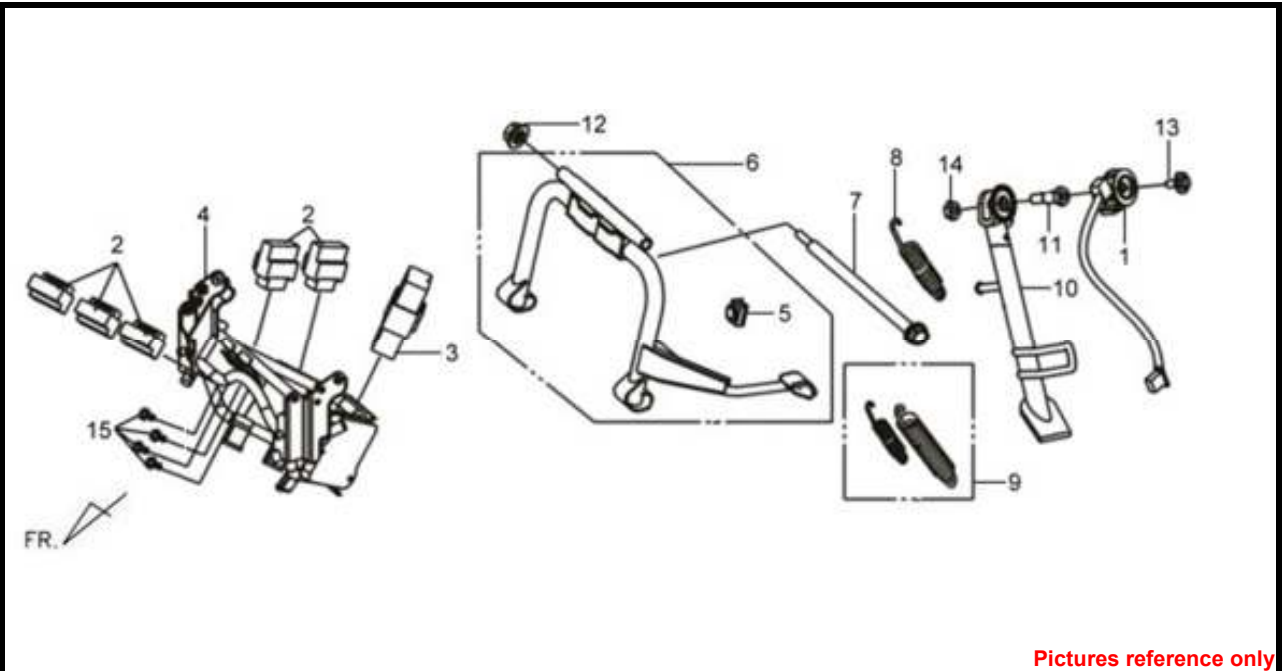

Pictures reference only

PARTS NUMBER	SELLING PRICE (RM/PCS)	DESCRIPTION	QTY	EFFECTIVE DATE	
1 36500-HMA-000	41.10	SIDE STAND SW COMP	1		
2 3850A-HLA-000	34.40	ELEC RELAY ASSY	2		
2 3850A-HLA-010	34.40	ELEC RELAY ASSY	2	2010/11/23	N
2 3850A-M8Q-000	32.60	ELEC RELAY ASSY	2	2011/11/25	
3 38720-HMA-000	102.90	HAZARD CTRL UNIT	1		
4 50315-HMA-000	167.90	FR COVER STAY ASSY.	1		
4 50315-HWF-000	164.50	FR COVER STAY	1	2103/7/2	N
5 50505-M92-010	3.60	STAND STOPPER RUB.	1		
6 5050A-HMA-000	132.30	MAIN STAND ASSY	1		
7 50512-H6B-000	10.90	MAIN STAND PIVOT BOLT	1		
8 5053A-HMA-000	5.80	SIDE STAND SPRING ASSY.	1		
9 5052A-H9A-000	6.10	MAIN STAND SPG.ASSY	1		
10 50530-HMA-000	30.80	SIDE STAND COMP	1		
11 90108-HMA-000	2.80	SIDE STAND PIVOT SCREW	1		
12 90304-M9Q-000	4.80	NUT U FLANGE 10MM	1		
13 93404-06016-07	0.80	BOLT WASHER 6X16	1		
14 94002-08080-0S	1.00	HEX NUT 8MM	1		
15 95801-06012-08	0.80	FLANGE BOLT	4		

※ Please check the color & stripe information according to the color index !

※N/A = SUBSTITUTE

※Y = EXCHANGEABLE

※N = NOT AVAILABLE



TEAN WORLDWIDE. 2009.08

PRICE SHOWN IS PER PIECE. Product image price are approximate guide only.
Prices shown are subject to change without prior notice.

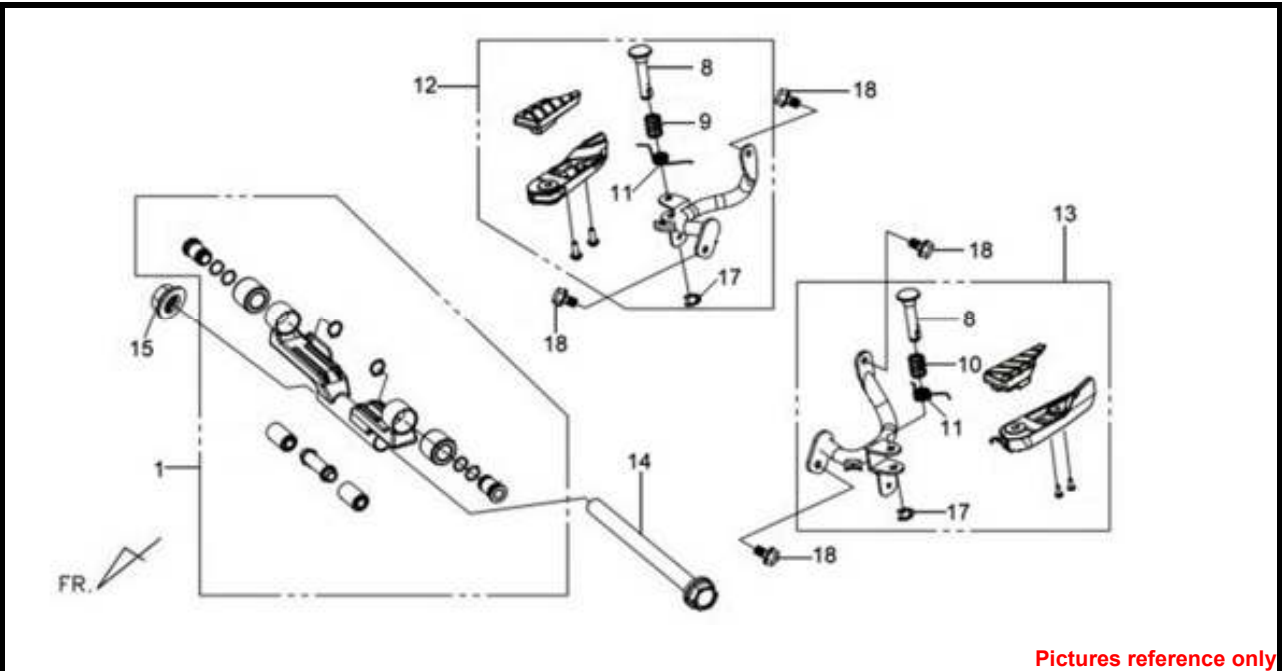

Pictures reference only

PARTS NUMBER	SELLING PRICE (RM/PCS)	DESCRIPTION	QTY	EFFECTIVE DATE
1 50350-HMA-010	233.00	ENG. HANGER LINK ASSY.	1	
8 50625-HMA-000	17.80	PILLION STEP PIN	2	
9 50626-HMA-000	1.70	R. PILLION STEP SPG	1	
10 50627-HMA-000	1.70	L. PILLION STEP SPG	1	
11 50629-HMA-000	1.70	RETURN SPG	2	
12 5062A-HMA-000	161.10	R PILLION STEP ASSY.	1	
13 5062B-HMA-000	161.10	L PILLION STEP ASSY.	1	
14 90105-HMA-000	12.10	FLANGE BOLT	1	
15 90306-M9Q-000	6.10	SELF LOCK NUT 12MM	1	
17 94540-07010	1.30	E-RING 7MM	2	
18 95801-08020-08	1.00	FLANGE BOLT	4	

※ Please check the color & stripe information according to the color index !

※N/A = SUBSTITUTE

※Y = EXCHANGEABLE

※N = NOT AVAILABLE



TEAM WORLD BROS. 2009.08

F17 FRAME BODY

LM25W5-MC(GTS250 EFI CKD TO 馬來西亞)

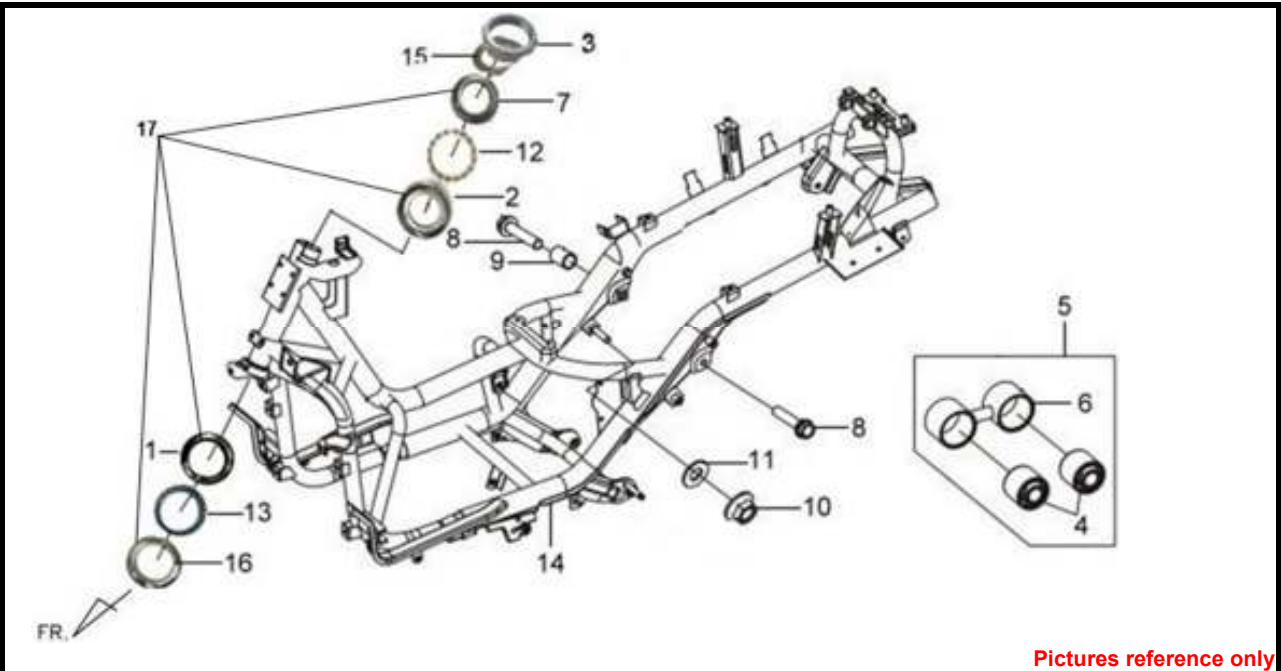

Pictures reference only

PARTS NUMBER	SELLING PRICE (RM/PCS)	DESCRIPTION	QTY	EFFECTIVE DATE
1 50305-VA3-000	12.10	STRG.BOTTOM BALL RACE	1	
2 50301-HMA-000	10.90	RACE UP STRG BALL	1	
3 50306-M9Q-000	5.50	STRG. STEM LOCK NUT	1	
4 50356-HMA-000	22.30	STOPPER RUBBER BUSH	2	
5 50380-HMA-000	63.40	TENSION ROD ASSY.	1	
6 50381-HMA-000	17.10	TENSION ROD	1	
7 53211-HMA-000	12.10	STRG. UP CONE RACE	1	
8 90106-HHA-000	3.30	FLANGE BOLT 12*55	2	
9 90121-HHA-000	6.00	DISTANCE COLLAR	1	
10 90306-M9Q-000	6.10	SELF LOCK NUT 12MM	1	
11 94103-12800	1.30	PLAIN WASHER	1	
12 53215-HMA-000	25.60	STEEL BALL UP ASSY.	1	
13 53225-HMA-000	26.10	STEEL BALL LOW ASSY.	1	
14 50100-HML-000	1919.50	FRAME BODY COMP	1	
15 50308-HMA-000	1.70	STRG STEM WASHER	1	
16 53212-VA3-000	12.10	STRG BOTTOM CONE RACE	1	
17 50300-HMA-000	51.70	BALL RACE SET	1	

※ Please check the color & stripe information according to the color index !

※N/A = SUBSTITUTE

※Y = EXCHANGEABLE

※N = NOT AVAILABLE



TEAM WORLD BROS. 2009.08

PRICE SHOWN IS PER PIECE. Product image price are approximate guide only.
Prices shown are subject to change without prior notice.

F18 MUFFLER ASSY

LM25W5-MC(GTS250 EFI CKD TO 馬來西亞)

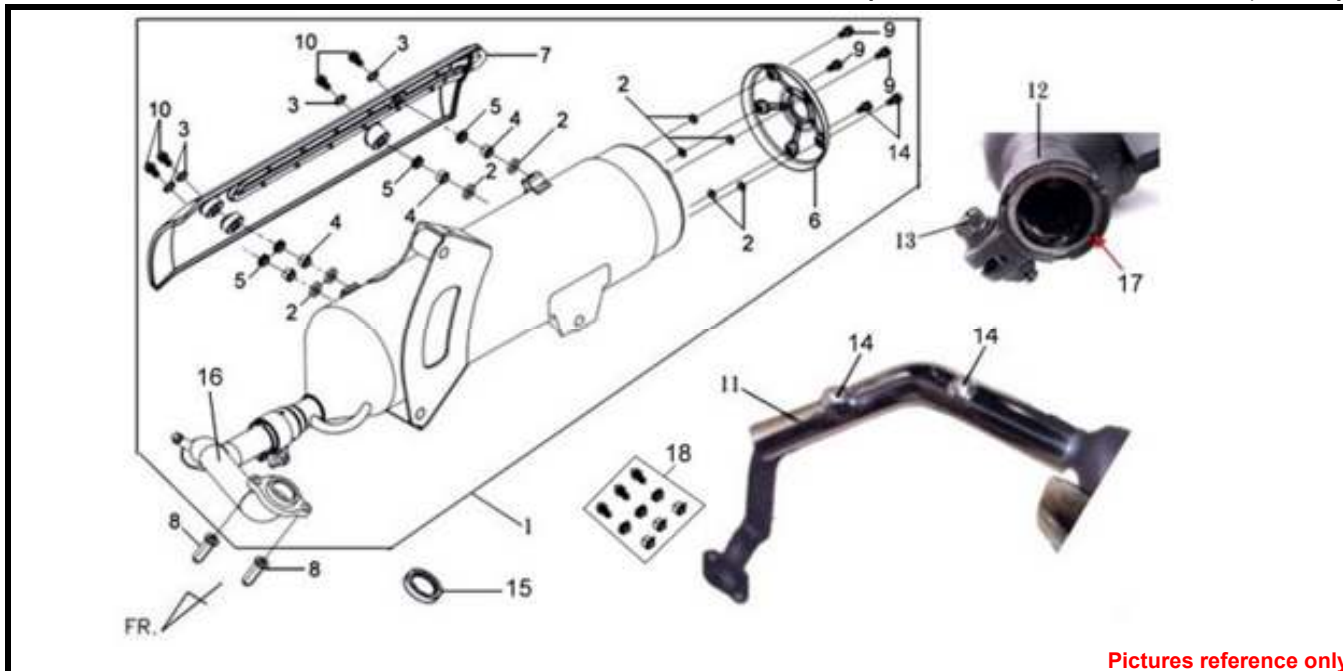

Pictures reference only

PARTS NUMBER	SELLING PRICE (RM/PCS)	DESCRIPTION	QTY	EFFECTIVE DATE	
1 18000-HML-000	2161.00	EXH.MUFFLER ASSY	1		
2 18292-F3E-000	4.10	PROTECTOR PACKING A	8		
3 18293-F3E-000	1.00	PROTECTOR PACKING	3		
4 18295-A1A-000	2.80	COLLAR M6	3		
5 18320-F3E-000	2.50	PROTECTOR RUBBER	3		
5 18321-L1A-000	3.30	PROTECTOR RUBBER	3	17/6/2013	N
6 18328-HLK-000	56.60	MUFFLER REAR PROTECTOCR	1		
7 18318-HMA-300	96.00	MUFFLER PROTECTOR	1		
8 90043-HMA-000	4.10	CAP NUT	2		
9 90103-H13-000	1.70	SH. FLANGE BOLT 6X16	3		
10 93401-06022-07	1.00	WASHER BOLT 6X22	4		
11 18241-HMA-020	37.70	EXH. PIPE PROTECTOR	1		
12 18321-HMA-000	18.90	MUFFLER BAND 37MM	1		
13 95801-08035-07	1.70	FLANGE BOLT M8X35	1		
14 90103-V02-000	1.70	FLANGE SH BOLT SET 6X12(SILVER)	2		
14 90103-V02-100	1.70	FLANGE SH BOLT SET 6X12(BLACK)	2		
15 18291-H9A-000	6.90	EXHAUST PIPE GASKET	1		
16 18320-HML-300	189.90	EXHAUST PIPE	1		
17 18319-HMA-300	30.80	MUFFLER GASKET	1		
18 H2B-6	24.00	MUFFLER COVER NUT SET	1		

※ Please check the color & stripe information according to the color index !



※N/A = SUBSTITUTE

※Y = EXCHANGEABLE

※N = NOT

TEAMWORLD LTD. 2009.08

PRICE SHOWN IS PER PIECE. Product image price are approximate guide only.
Prices shown are subject to change without prior notice.

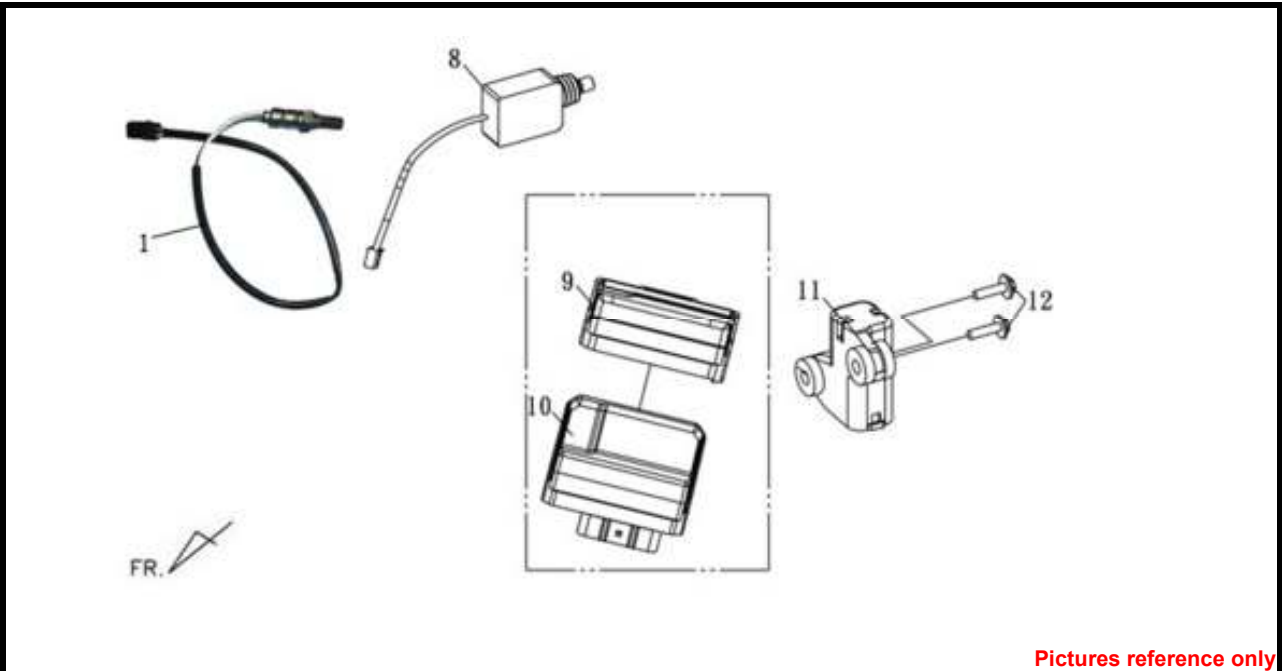

Pictures reference only

PARTS NUMBER	SELLING PRICE (RM/PCS)	DESCRIPTION	QTY	EFFECTIVE DATE
1 37890-A5L-000	392.50	O2 SENSOR	1	
8 35880-HMB-000	75.40	LINER MOTOR ASSY.	1	
9 64321-A5L-000	5.20	ECU SUSPENSION	1	
10 38710-HML-010	797.00	ENG. CONT UNIT	1	
11 36100-A5L-100	118.30	ROLL OVER SENSOR ASSY	1	
12 93894-04022-08	1.00	WASHER SCREW	2	

※ Please check the color & stripe information according to the color index !

※N/A = SUBSTITUTE

※Y = EXCHANGEABLE

※N = NOT AVAILABLE



TEAM WORLD BINA. 2009.08

PRICE SHOWN IS PER PIECE. Product image price are approximate guide only.
Prices shown are subject to change without prior notice.

F20 AIRCLEANER ASSY

LM25W5-MC(GTS250 EFI CKD TO 馬來西亞)

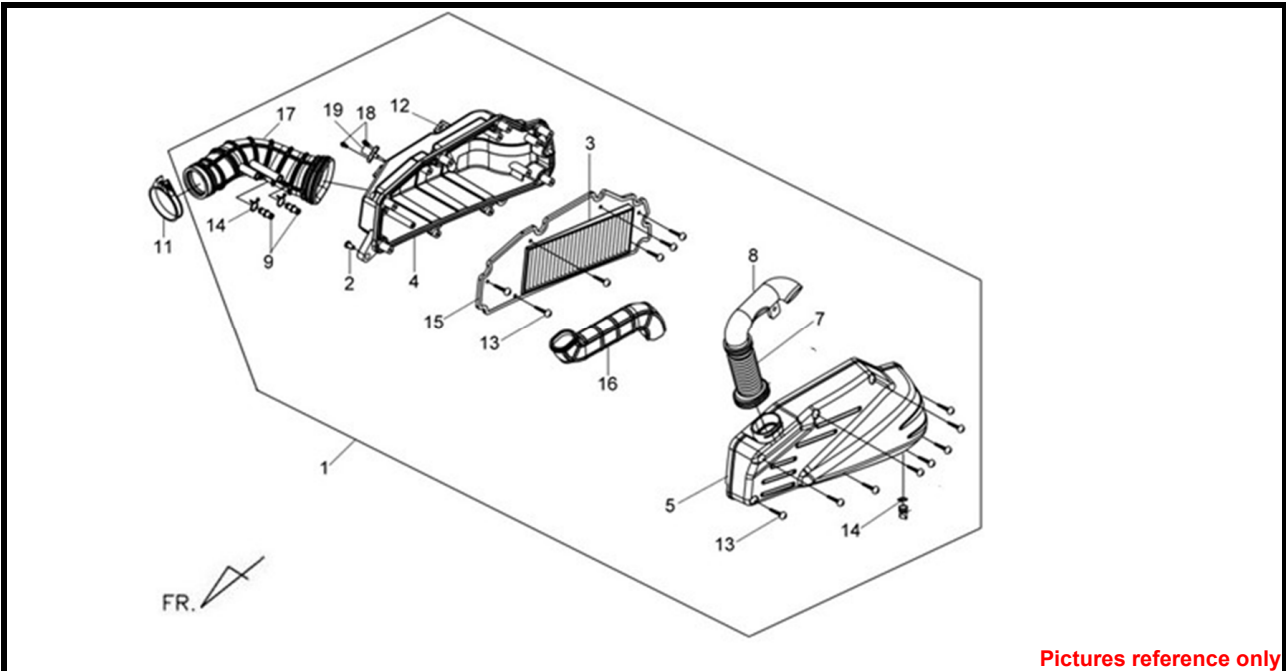

Pictures reference only

PARTS NUMBER	SELLING PRICE (RM/PCS)	DESCRIPTION	QTY	EFFECTIVE DATE
1 17200-HML-000	262.20	AIR/C ASSY	1	
2 17208-HMA-000	3.30	AIR/C SET COLLAR	2	
3 17211-HMA-000	56.60	AIR/C ELEMENT COMP	1	
4 17230-HMC-000	44.60	AIR/C CASE COMP	1	
5 17231-HMA-000	41.10	AIR CLEANER CASE.	1	
7 17257-HMA-000	17.10	AIR/C DUCT A	1	
8 17258-H9A-000	15.40	AIR/C CASE DUCT	1	
9 17359-M9Q-000	3.30	BREATHER TUBE JOINT	2	
11 90652-HMA-000	8.60	AIR/C CONN.TUBE BAND 48	1	
12 90677-GR1-003	2.00	CLIP NUT 5MMX0.8	2	
13 93903-25480	0.60	TAPPING SCREW 5X20	14	
14 95002-80000	1.00	TUBE CLIP C12	2	
15 17214-HMA-000	6.90	AIR/C COVER SEAL	1	
16 17255-HMA-000	21.20	AIR/C INLET DUCT	1	
17 17253-HMA-000	36.00	AIR/C CONN TUBE	1	
18 93891-05016-07	1.30	WASH SCREW 5X16	2	
19 37830-HMC-000	47.90	AIR TEMP SENSOR	1	

※ Please check the color & stripe information according to the color index !



※N/A = SUBSTITUTE

※Y = EXCHANGEABLE

※N = NOT AVAILABLE. 2009.08

TEAM WORLD

PRICE SHOWN IS PER PIECE. Product image price are approximate guide only.
Prices shown are subject to change without prior notice.

PARTS NO.	NO.		PARTS NO.	NO.		PARTS NO.	NO.	
6000			12391-HMA-000	E01		15421-B9D-000	E07	
06414-HMC-000	E02		13000			15421-M9Q-000	E07	
06415-A5L-000	E02		13000-HML-010	E12		15426-M9Q-000	E07	
06416-A5L-000	E02		13010-HMA-000	E03		1565A-HMA-000	E07	
11000			13101-HMA-000	E03		15711-HML-000	E13	
11100-HMA-001	E06		13111-HMA-000	E12		15772-500-013	E15	
11107-HMA-000	E07		13201-LEA-000	E12		16000		
11120-HMA-000	E06		13371-HMA-300	E12		1614-906-0002	E02	
11120-HMA-000	E08		13381-HMA-300	E12		16201-HMC-000	E02	
11191-HMA-000	E06		14000			1621A-HMC-000	E02	
11200-HMA-000	E08		14100-HML-000	E02		16401-HWA-000	E02	
11203-M9Q-300	E08		14105-RFA-000	E04		1652-0029	F02	
11203-M9Q-300	F05		14105-X01-000	E04		1670A-LEA-000	F13	
11211-HMA-000	E15		14108-M36-000	E04		16711-M9Q-000	F13	
11221-HMA-000	E11		14151-RFA-000	E06		16712-M9Q-000	F13	
1122A-HMA-000	E11		1443A-HMA-000	E02		16730-HMC-000	F13	
11330-HMA-000	E07		1444A-HMA-000	E02		17000		
11330-LEA-000	E07		14451-HMA-000	E02		1711A-HMC-000	E02	
11341-HMA-000	E14		14457-HMA-000	E02		17120-HMC-000	E02	
11342-HMA-000	E14		14510-RFA-000	E03		17200-HML-000	F20	
11343-HMA-000	E14		14520-H6T-000	E03		17208-HMA-000	F20	
11344-HMA-000	E14		14522-H6T-000	E03		17211-HMA-000	F20	
11346-HMA-000	E14		14523-M9Q-000	E03		17214-HMA-000	F20	
11352-HMA-000	E14		14524-H6T-000	E03		17221-HMA-000	E14	
11353-HMA-000	E14		14525-H6T-000	E03		17230-HMC-000	F20	
1135A-HMA-000-KB	E14		14531-KJ9-000	E03		17231-HMA-000	F20	
1137A-HMA-000	E14		14610-RFA-000	E03		17253-HMA-000	F20	
11394-HMA-000	E05		14711-HMA-000	E02		17255-HMA-000	F20	
11395-HMA-000	E14		14721-HMA-000	E02		17257-HMA-000	F20	
12000			14751-HMA-000	E02		17258-H9A-000	F20	
12100-HMA-000	E03		14761-HMA-000	E02		17359-M9Q-000	F20	
12100-HMA-000-A	E03		14771-M8Q-000	E02		17369-KB4-670	E15	
12191-HMA-000	E03		14777-KN7-670	E02		17369-KB4-670	F13	
12200-HMC-000	E02		14781-M9Q-000-A	E02		17370-M9Q-000	E15	
12209-H6B-900	E02		1484-0031	F02		17371-M9Q-000	E15	
12251-HMA-000	E03		1484-0039	F02		1738A-HMB-000	E15	
12301-HMA-000	E01		15000			17500-HMC-000	F13	
1231A-HMA-000	E04		15100-HMA-000	E13		17508-HMA-000	F13	
12342-X01-000	E02		15126-B8A-000	E13		17509-HMA-000	F13	
1236A-V02-000	E07		15133-HMA-000	E13		17562-HMA-000	E15	

PARTS NO.	NO.		PARTS NO.	NO.		PARTS NO.	NO.	
17571-HMC-000	E15		19020-HMA-000	F07		22132-HMA-000-A	E09	
17574-HMC-000	E15		19101-HMA-000	F06		222Y-0035	F02	
17576-HMC-000	E15		19102-HMA-000	F06		222Y-0038	F02	
1757A-HMC-000	E15		19215-HLA-000	E07		22300-HMB-000	E10	
17581-HMA-000	F13		19217-H9A-300	E07		22350-HMA-000	E10	
17585-HMA-000	F13		19229-H9A-000	E07		22361-HMA-000	E10	
17590-HMC-000	E15		1922A-HMA-000	E07		22401-HMA-000	E10	
17651-HMA-000	F13		1922A-LEA-000	E07		22530-HMB-000-A	E10	
17652-TAA-000	F13		19231-HMA-000	E07		22804-HMA-000	E10	
17653-HMA-000	F13		19300-HMA-000	E02		23000		
17654-HMA-000	F13		19315-KJ9-000	E02		23010-HMB-000	E10	
17661-HMA-000	F06		19501-HTA-000	F07		23200-HMA-000	E10	
1766A-HMA-000	F13		19501-HTA-900	F07		23220-HMA-000	E10	
17910-HMA-000	F02		19503-HMA-000	F07		23225-HMA-000	E10	
17920-HMA-000	F02		19505-H5D-900	F07		23226-HMA-000	E10	
18000			19505-H5D-900	F13		23233-HMA-000	E10	
18000-HML-000	F18		19505-HMA-000	F07		23237-HMA-000	E10	
18241-HMA-020	F18		19505-HMA-900	F07		23238-HMA-000	E10	
18291-H9A-000	F18		19505-KS6-700	E07		23411-HMA-000	E11	
18292-F3E-000	F18		19505-KS6-700	F07		23420-HMA-000	E11	
18293-F3E-000	F18		19505-M8Q-000	F07		23421-HMA-300	E11	
18295-A1A-000	F18		19505-REA-000	F07		23422-HMA-300	E11	
18318-HMA-300	F18		19506-HMA-000	F07		23431-HMA-000	E11	
18319-HMA-300	F18		19506-HMA-900	F07		23432-HMA-000	E11	
18320-F3E-000	F18		19507-HMA-000	F07		28000		
18320-HML-300	F18		19509-HTA-900	F07		28100-HMA-000	E06	
18321-HMA-000	F18		19509-HWA-000	F07		28102-HMA-000	E06	
18328-HLK-000	F18		1950A-HMA-000	E07		28110-HMA-000	E05	
18610-HKA-000	E01		1951A-HMA-000	E02		2812A-HMA-000	E05	
18647-HMA-000	E01		19604-H01-000	E07		30000		
18654-N14-000	E01		21000			3043A-REA-000	F14	
19000			21200-HMA-000	E11		3051A-HMA-010	F14	
19000-HMA-000	F07		21395-HMA-000	E11		31000		
19000-HMA-900	F07		22000			31110-HMC-000	E05	
19010-HMA-000	F07		22101-HMA-000	E10		31120-HMC-000	E05	
19010-HMA-900	F07		22102-HMA-000	E09		31200-HMA-000	E06	
19015-HMA-000	F06		22105-HMA-000	E09		31600-HMA-000	F14	
19016-HMA-000	F06		22110-HMA-000	E09		31600-HMA-010	F14	
19017-HMA-000	F13		22121-RB1-001-A	E09		31600-HMA-020	F14	
19018-HMA-000	F13		22131-HMA-000	E09		32000		

PARTS NO.	NO.		PARTS NO.	NO.		PARTS NO.	NO.	
32100-HML-010	F14		35200-HNL-000	F02		42753-KBN-902	F04	
32100-HML-020	F14		35340-KBN-900	F02		42753-M92-300	F05	
32100-HML-110	F14		35350-KBN-900	F02		43000		
32160-A3A-900	F02		35360-HMA-000	F06		43100-HMA-000	F02	
32411-HMA-000	F14		35370-M9P-000	F09		43105-HMA-000-A	F02	
32412-HMA-000	F14		35380-HMA-000	F09		43121-HMA-000	F05	
32415-HMA-010	F14		35860-HMC-000	F14		43311-HMA-000	F02	
33000			35860-HMC-010	F14		43312-HMA-000	F02	
33100-HWA-000	F01		35880-HMB-000	F19		43313-HMA-000	F02	
33101-HWA-000	F01		36000			43500-HMA-000	F02	
33102-HWA-000	F01		36100-A5L-100	F19		44000		
33124-HWA-000	F01		36500-HMA-000	F15		44301-G22-000	F04	
33151-HWA-000	F01		36600-A1A-000	F09		44311-GW0-910	F04	
33152-HWA-000	F01		37000			44312-HMA-000	F04	
33190-HWA-000	F01		37200-HT2-000	F11		44601-HMA-000	F04	
33195-HWA-000	F01		37211-HMA-000	F11		44620-H3A-000	F04	
33400-HMA-000	F01		37750-PC1-004	E02		44710-HMA-010	F04	
33450-HMA-000	F01		37760-HMA-000	F07		44720-H9A-000	F04	
33700-HMA-000	F08		37800-HWA-000	F13		44720-H9A-000	F05	
33701-HMA-000	F08		37801-A5L-000	F13		44800-HMB-000	F04	
33711-HMA-000	F08		37830-HMC-000	F20		45000		
33721-HMA-000	F08		37880-HMC-000	E02		45100-HMA-000	F02	
33740-HMA-000	F12		37890-A5L-000	F19		45105-HMA-000-A	F02	
33741-M9A-000	F12		38000			45121-HMB-000-SH	F04	
34000			38110-HMA-000	F14		45126-HMA-000	F02	
34901-LVA-000	F01		3850A-HLA-000	F15		45156-H3C-000	F12	
34902-HMA-000	F11		3850A-HLA-010	F15		45500-HMA-000	F02	
34905-HMA-000	F01		3850A-M8Q-000	F15		46000		
34905-HMA-000	F01		38600-RA1-000	F06		46300-HMA-000	F02	
34905-HMA-000	F08		38600-RA1-000	F14		50000		
34906-HMA-000	F08		38710-HML-000	F19		50100-HML-000	F17	
34907-HMA-000	F11		38710-HML-010	F19		50300-HMA-000	F17	
34909-HMA-000	F01		38720-HMA-000	F15		50301-HMA-000	F17	
34909-HMA-000	F01		38800-H5B-000	F14		50305-VA3-000	F17	
35000			40000			50306-M9Q-000	F17	
35010-HMA-100	F14		4000-452-0003	E02		50308-HMA-000	F17	
35110-HMA-000	F14		42000			50315-HMA-000	F15	
35111-HMA-100-A01	F14		42311-H9A-000	F05		50326-HMA-000	F06	
35111-HMA-100-B01	F14		42311-H9A-900	F05		50350-HMA-010	F16	
35150-HM1-000	F02		42601-HMA-000	F05		50356-HMA-000	F17	

PARTS NO.	NO.		PARTS NO.	NO.		PARTS NO.	NO.	
50380-HMA-000	F17		53211-HMA-000	F17		64321-HMA-000	F10	
50381-HMA-000	F17		53212-VA3-000	F04		64322-HMA-000	F10	
50505-M92-010	F15		53212-VA3-000	F17		64323-HMA-000	F10	
5050A-HMA-000	F15		53214-HMA-000	F04		64324-HMA-000	F10	
50512-H6B-000	F15		53215-HHA-000	F04		6432C-HMA-000	F10	
5052A-H9A-000	F15		53215-HMA-000	F17		67000		
50530-HMA-000	F15		53225-HMA-000	F17		67101-HMA-000	F11	
5053A-HMA-000	F15		55000			6710A-HWA-000	F11	
50611-HMA-000	F12		5520A-KBN-900	E11		67111-HWA-000	F11	
50625-HMA-000	F16		61000			6711A-HWA-000	F11	
50626-HMA-000	F16		61100-HMA-000-IP	F04		74000		
50627-HMA-000	F16		61100-HMA-000-JG	F04		74480-HMA-010	F09	
50629-HMA-000	F16		61100-HMA-000-QU	F04		74481-HMA-000	F09	
5062A-HMA-000	F16		61100-HMA-000-SO	F04		75000		
5062B-HMA-000	F16		61101-HWA-000	F01		75581-M9Q-000	F08	
51000			64000			77000		
51106-LEA-000	F04		64300-HMA-000-IP	F01		77200-HWA-000	F09	
51400-HWA-000	F04		64300-HMA-000-JG	F01		77200-HWA-010-T1	F09	
51410-HWA-000	F04		64300-HMA-000-QU	F01		77201-HMA-900	F09	
51410-HWA-000	F04		64300-HMA-000-SO	F01		77203-HMA-010	F09	
51500-HWA-000	F04		64301-HWA-000-IP	F01		77204-HMA-000	F09	
52000			64301-HWA-000-JG	F01		77230-HMB-000	F08	
5210A-HMA-005	F05		64301-HWA-000-QU	F01		77233-HMA-000	F14	
52400-HMA-000	F05		64301-HWA-000-SO	F01		77236-HAA-000	F08	
53000			64301-HWA-010-IP	F01		77239-HMA-000	F08	
53100-HMA-000	F02		64301-HWA-010-JG	F01		77240-HMA-000	F08	
53104-N02-000	F02		64301-HWA-010-QU	F01		77300-HWA-000	F09	
53125-M9Q-000	F02		64301-HWA-010-SO	F01		77300-HWA-010-T1	F09	
53140-HMA-900	F02		64304-X01-000	F01		77400-HWA-000-IP	F08	
53166-H85-000	F02		64304-X01-000	F11		77400-HWA-000-JG	F08	
53175-HMA-000	F02		64310-HMA-020-KA	F10		77400-HWA-000-QU	F08	
53178-HMA-000	F02		64311-HMA-020-KA	F10		77400-HWA-000-SO	F08	
53200-HWA-000	F04		64312-HMA-000	F10		80000		
53204-HMA-900	F02		64312-HMA-000	F11		80100-HMA-000	F12	
53205-HMA-900-KA	F02		64313-HMA-000	F10		80102-HMA-000	F12	
53206-HMA-900	F02		64314-HMA-000	F10		80104-HMA-000	F09	
53207-HMA-900	F02		64315-HMA-000	F10		80106-HMA-000	F12	
53208-HMA-020	F11		64315-HMA-000	F11		81000		
53208-HMA-030	F11		64319-HMA-000-KA	F10		81131-HMA-000-KA	F06	
53209-HMA-000	F11		64321-A5L-000	F19		81134-HMA-000	F11	

PARTS NO.	NO.		PARTS NO.	NO.		PARTS NO.	NO.	
81141-HMA-000	F06		8362G-HWA-000-JG	F10		88110-HMA-900-IP	F03	
81142-HMA-000	F06		8362G-HWA-000-QU	F10		88110-HMA-900-JG	F03	
81143-HMA-000	F06		8362G-HWA-000-SO	F10		88110-HMA-900-QU	F03	
81144-HMA-000	F06		83630-HMA-000	F09		88110-HMA-900-SO	F03	
81146-HMA-000	F06		87000			88111-HMA-000	F03	
81151-HMA-020	F11		87121-H85-000	F11		88112-HMA-000	F03	
81151-HMA-030	F11		87123-HEB-000	F02		88120-HMA-900-IP	F03	
81152-HMA-000	F11		87123-HWA-000-S	F10		88120-HMA-900-JG	F03	
81153-HMA-010	F10		87123-HWA-000-S	F10		88120-HMA-900-QU	F03	
81153-HMA-010	F11		87123-HWA-000-S	F10		88120-HMA-900-SO	F03	
8115A-HMA-010	F11		87123-HWA-000-S	F10		88121-HMA-000	F03	
8115B-HMA-000	F11		87123-HWA-000-S	F10		88122-HMA-000	F03	
81200-HWA-000-IP	F08		87123-HWA-000-S	F10		89000		
81200-HWA-000-JG	F08		87123-HWA-000-S	F10		89010-M92-000	F03	
81200-HWA-000-QU	F08		87123-HWA-000-S	F10		90000		
81200-HWA-000-SO	F08		87123-HWA-000-S	F11		90001-M9Q-000	E03	
81210-HMA-000	F08		87123-TFS-000	F11		90002-HMA-000	E01	
81211-HWA-000-IP	F08		87125-HMA-000	F11		90012-HLK-000	E02	
81211-HWA-000-JG	F08		87126-HM1-000	F08		90031-HMA-000	E06	
81211-HWA-000-QU	F08		87126-HM1-000	F08		90032-HMA-000	E02	
81211-HWA-000-SO	F08		87126-HM1-000	F08		90032-HMA-000	E08	
81257-HMA-000	F09		87126-HM1-000	F08		90043-HMA-000	F18	
8125A-HMA-008	F09		87127-HM1-000	F08		90085-HHA-900	F14	
8125B-HML-000	F09		87127-HM1-000	F08		9008A-H9A-000	E07	
83000			87127-HM1-000	F08		90103-H13-000	F18	
83501-HMA-000-OL	F08		87127-HM1-000	F08		90103-HWA-000	F04	
8350G-HM1-000-IP	F08		87129-HML-000	F08		90103-HWA-000	F04	
8350G-HM1-000-JG	F08		87129-HML-000	F08		90103-M9Q-000	E08	
8350G-HM1-000-QU	F08		87129-HML-000	F08		90103-V02-000	F18	
8350G-HM1-000-SO	F08		87129-HML-000	F08		90103-V02-100	F18	
8352G-HWA-000-IP	F10		87129-HML-000	F08		90104-H5K-000	F02	
8352G-HWA-000-JG	F10		87129-HML-000	F08		90104-H9A-000	F02	
8352G-HWA-000-QU	F10		87129-HML-000	F08		90105-HMA-000	F16	
8352G-HWA-000-SO	F10		87129-HML-000	F08		90105-HMC-000	F13	
83601-HMA-000-OL	F08		87129-LEA-000	F01		90105-KR3-000	F04	
8360G-HM1-000-IP	F08		87129-LEA-000	F01		90105-KR3-000	F05	
8360G-HM1-000-JG	F08		87129-LEA-000	F01		90106-H2G-000	F08	
8360G-HM1-000-QU	F08		87129-LEA-000	F01		90106-HHA-000	F17	
8360G-HM1-000-SO	F08		87505-HMA-000	F09		90106-HMA-000	F09	
8362G-HWA-000-IP	F10		88000			90106-M9Q-000	F02	

PARTS NO.	NO.		PARTS NO.	NO.		PARTS NO.	NO.	
90108-HMA-000	F15		90481-M9Q-000	E08		91308-HMA-000	E02	
90110-FYA-000	F14		90481-M9Q-100	E08		91309-HWA-000	F04	
90111-HKD-000	F06		90545-M9Q-000	F02		91309-HWA-000	F04	
90111-M9Q-800	F09		90601-HMA-000	E12		92000		
90111-M9Q-900	F06		90602-HMA-000	E10		92101-06016-0H	E04	
90111-M9Q-900	F12		90652-HMA-000	F20		92800-12000	E08	
90118-HLK-000	F01		90677-M9Q-000	F09		93000		
90119-HMA-000	F11		90677-M9Q-000	F12		93401-06022-07	F18	
90121-HHA-000	F17		90677-M9Q-000	F20		93404-06016-07	F01	
90145-M9Q-000	F02		90682-V02-900	E15		93404-06016-07	F15	
90157-F3G-000	E05		90701-HB6-010	E12		93404-06016-08	F12	
90164-M9Q-000	F04		90754-M9Q-000-M2	F04		93404-06016-08	F13	
90201-KR8-751-M1	E05		90912-M9Q-000-M1	F04		93404-06020-08	F07	
90201-KR8-751-M1	E09		91000			93405-06012-08	F07	
90201-KR8-751-M1	E10		91001-HMA-000	E12		93406-05010-07	F09	
90202-HMA-000	E10		91001-KJ9-005	E07		93406-08012-00	F08	
90206-HLK-000	E02		91002-HMA-000	E11		93406-08020-07	F08	
90301-GE0-000	F09		91003-HML-000	E12		93500-05012-0H	E14	
90302-M92-000	F01		91003-LEA-000	E12		93500-05016-0A	E05	
90302-M92-000	F02		91006-HMA-300	E10		93500-06025-0H	E13	
90302-M92-000	F06		91007-HMA-300	E10		93891-05012-07	F02	
90302-M92-000	F08		91009-HMC-000	E11		93891-05016-07	F09	
90302-M92-000	F09		91101-HMA-000	E13		93891-05016-07	F10	
90302-M92-000	F10		91201-HMA-300	E12		93891-05016-07	F12	
90302-M92-000	F11		91202-HMA-000	E05		93891-05016-07	F20	
90304-M9Q-000	F02		91203-HMA-000	E11		93891-05040-07	F12	
90304-M9Q-000	F15		91204-HMA-000	E11		93891-06050-07	F04	
90305-M9Q-000	F04		91205-KF0-003	E07		93893-06016-07	F04	
90305-M9Q-900	F05		91211-HMA-000	E10		93893-06016-07	F13	
90306-M9Q-000	F04		91255-HWA-000	F04		93894-04022-08	F19	
90306-M9Q-000	F16		91255-HWA-000	F04		93903-25320	F01	
90306-M9Q-000	F17		91256-HWA-000	F04		93903-25320	F06	
90401-HMA-000	E11		91256-HWA-000	F04		93903-25320	F11	
90401-KJ9-000	E05		91259-HWA-000	F04		93903-25480	F20	
90401-KJ9-000	E09		91259-HWA-000	F04		93903-34320	F01	
90401-KJ9-000	E10		91301-HMA-000	E04		93903-34320	F02	
90423-KJ9-000	E07		91302-M9Q-000	E07		93903-34320	F06	
90442-HMA-000	E02		91303-M2Q-000	E07		93903-34320	F10	
90474-M9Q-000	E08		91305-HMA-000	E10		93903-34320	F11	
90478-700-000	E07		91307-M9Q-000	E07		93903-34320	F12	

PARTS NO.	NO.		PARTS NO.	NO.		PARTS NO.	NO.	
93903-34380	F02		95801-06012-08	F08		96140-62013-10	E05	
93903-34380	F06		95801-06012-08	F15		96150-60060-10	E14	
93903-34380	F08		95801-06016-08	F14		96150-62050-10	E11	
93903-34380	F09		95801-06022-07	F02		96150-63033-10	F05	
93903-34380	F09		95801-08016-08	F14		DRIVE BELT		
93903-34380	F10		95801-08020-08	F16		1B01HMA01	E10	
93903-34380	F11		95801-08035-07	F05		CAM CHAIN		
93903-34380	F12		95801-08035-07	F18		1C14401-RFA-000	E04	
93903-34380	F13		95801-08050-08	E08		1C15141-HMA-000	E13	
93903-44380	F10		95801-10040-08	F04		SPARK PLUG		
94000			95801-10040-08	F05		1PCR8E-3	E02	
94002-08080-0S	F15		95801-10065-07	F05		TIRE		
94050-05080	F12		95801-10075-07	F05		1T011307013-4PR-6029	F05	
94050-06000	E02		96000			OTHER		
94050-06080	F09		96001-06010-00	E07		1V93-0228	F02	
94050-10080	E02		96001-06010-08	E06		BATTERY		
94101-08800	F09		96001-06010-08	E13		1Y01HMA01-Y	F03	
94103-12800	F17		96001-06012-00	E14		OTHER		
94109-12000	E08		96001-06012-08	E06		2E34-0016	F02	
94251-08400	F09		96001-06014-00	E01		OTHER		
94301-08140	E05		96001-06014-00	E02		H2B-6	F18	
94301-08140	E06		96001-06016-00	E01				
94301-08140	E07		96001-06016-00	E01				
94301-08140	E11		96001-06016-00	E02				
94301-12200	E03		96001-06018-00	E04				
94510-10000	E13		96001-06018-07	E14				
94510-25000	E11		96001-06022-00	E06				
94520-26000	E07		96001-06022-00	E07				
94524-47000	F05		96001-06030-00	E14				
94540-07010	F16		96001-06032-00	E07				
94540-08010	E10		96001-06035-00	E14				
95000			96001-06045-00	E07				
95002-02080	E11		96001-06050-00	E08				
95002-02080	F13		96001-06055-00	E06				
95002-80000	E15		96001-06070-00	E08				
95002-80000	F20		96001-06090-00	E02				
95003-23032-60	E15		96100-60000-00	E07				
95005-45100-20	F13		96100-62040-10	E11				
95701-10012-08	E08		96100-62070-10	E12				
95801-06012-07	F06		96100-63020-00	E11				